



# Commercial Duct Heaters

Our products do more in a wide range of applications. **Expect More.**

## Choosing Open Coil or Finned Tubular Design

### Specific Requirements

- 6 Calculating KW Requirements
- 7 Static Pressure Drop
- 8 Minimum Velocity
- 8 Maximum Velocity
- 9 Airflow Uniformity
- 10 Multiple Heaters in the Duct
- 10 Clearance
- 11 UL and NEC Requirements
- 11 International Requirements

### Installation Information

- 12 Heater Installation
- 12 Field Wiring

### Standard Control Options

- 13 Internal Wiring
- 14 Control Option G – Basic
- 14 Control Option J – Pneumatic
- 15 Control Option K – Proportional
- 16 Thermostats

### Construction – Electrical

- 18 Bi-Metallic Thermal Cutouts
- 18 Linear Thermal Cutouts
- 19 Airflow Switch
- 19 Fan Relay
- 20 Magnetic Contactors
- 20 Fuses
- 20 Control Transformer
- 20 Disconnect Switch
- 21 Pilot Lights
- 21 Pilot Switch
- 21 Pneumatic/Electric (PE) Switches
- 22 Electronic Controls
- 22 SCR Power Controllers
- 23 Step Controllers (Sequencers)
- 24 Step Controllers (Microprocessor-based)
- 24 Vernier Proportional Control
- 25 Thermostats/Inputs for Electronic Controls

### Construction – Mechanical

- 26 Slip-in Heaters
- 26 Flanged Heaters
- 26 Zero Clearance Construction
- 27 Physical Standards

### Standard Duct Heaters – Open Coil

- 28 QUA Slip-in and QUZ Flanged Heaters
- 28 KW Ratings
- 28 Frame Sizes
- 29 Sizes and Maximum KW Ratings
- 30 Detail Dimensions
- 30 Voltage and Phase
- 30 Control Circuit Options & Special Features
- 30 Number of Heating Stages
- 30 Special Features
- 31 QUA/QUZ – Sample Specification

## Custom Duct Heaters

- 36 Special Applications
- 37 Round Duct Construction
- 38 Duct Heaters for Wet, Dusty and Corrosive Areas
- 39 Bottom Mounted Terminal Box
- 39 Insulated Terminal Box
- 39 Pressure Plates
- 40 Protective Screens
- 40 Unheated Sections
- 40 Construction for Lined Ducts
- 41 Slip-and-Drive Construction
- 41 Remote Panelboard
- 42 Minimum & Maximum Duct Dimensions
- 43 Open Coil Custom Heater – Sample Specification
- 44 Finned Tubular Custom Heater – Sample Specification

## Explosion-proof Duct Heaters

- 45 Safety
- 45 Experience
- 45 Complete Product Line
- 45 Applications
- 45 Use of Electric Heaters in Hazardous Areas
- 46 National Electrical Code Classification
- 46 Class
- 46 Division
- 47 Group
- 48 Engineering Information
- 48 Airflow Requirements
- 48 Comparison Chart

## ULTRA-SAFE™ Explosion-proof Duct Heaters

- 49 Standard Construction
- 50 Installation
- 51 Temperature Control
- 52 Standard Heater Listing
- 53 Custom Options
- 54 How to Order
- 54 Sample Specification

## Series EP2 Explosion-proof Duct Heaters

- 55 Standard Construction
- 55 Control Options
- 55 Installation
- 56 Custom Options
- 57 How to Order
- 57 Sample Specification

## Custom Explosion-proof Duct Heaters

- 58 Construction
- 59 How to Order
- 59 Sample Specification
- 60 Typical Wiring Diagrams

## More Indeeco Products

### Limited Warranty

# Choosing Open Coil or Finned Tubular Design

Indeeco manufactures both open coil (Figure 1) and finned tubular (Figure 2) heating elements and can supply virtually any duct heater with either type of element. While most simple space heating applications use the open coil design, there are many applications where finned tubular construction is appropriate. The following are the significant advantages of each type of construction.

## Open Coil

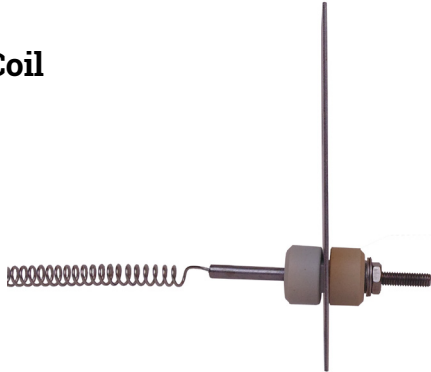

Figure 1.

Only the highest Grade A resistance wire (80% nickel, 20% chromium) is used in all Indeeco duct heaters. This iron-free wire has a higher maximum operating temperature, greater life, lower sag, less resistance change and higher corrosion resistance than other commonly used resistance wires.

Using calibrated tooling, the coils are mechanically crimped into stainless steel terminals. This connection, along with 10-32 terminal threads and stainless steel connection hardware, insures cool, minimum resistance, trouble free terminations.

An extended shank on the terminal places the critical resistance coil-to-terminal connection well out into the airstream to keep it cool even in applications where up to 1" of interior insulation is used in the duct.

Both terminal insulators and coil support insulators are fabricated from high-temperature ceramic. Their design and method of installation enable them to: 1) absorb both mechanical and thermal loading without chipping or cracking and 2) easily withstand high voltage dielectric tests.

**Element Temperature** – The open coil element releases its heat directly into the airstream. As a result, the open coil runs cooler than the coil in the finned tubular element which is isolated from the air by insulation and a metal sheath.

**Low Pressure Drop** – Because of the high percentage of open space across the heater, open coils have very low pressure drop as compared to finned tubular heaters. This can result in reduced fan motor horsepower and makes it possible to retrofit open coil heaters into existing systems without changing the fan motor.

**Large Electrical Clearances** – Generous electrical clearances between the coil and frame enable open coils to withstand severe applications such as subway car heating, where voltages may exceed 750 volts.

**Economy** – On relatively small, low KW heaters (the bulk of typical space heating applications) the open coil element is more economical. However, in large, high KW heaters, finned tubulars are more economical due to lower manufacturing costs.

**Smaller Size** – It is normally possible to get more KW with open coil construction for a given face area.

## Finned Tubular



Figure 2.

Finned tubular elements are designed and built by Indeeco to meet the requirements of each job. Length, wattage, voltage and element style are engineered to give the most economical package.

All elements consist of a Grade A coil (80% nickel, 20% chromium), precisely centered in a stainless steel tube which is filled with granular magnesium oxide. The entire assembly is compacted to maximize both the heat transfer and dielectric properties of the magnesium oxide. After compaction the tube measures 0.475" (12 mm) O.D., an unusually large diameter providing sufficient insulation for operation up to 600 volts.

A stainless steel fin is helically wound onto the tube to increase its heat transfer surface.

Indeeco has standardized on stainless steel for its finned tubular elements because of its superior resistance to moisture and corrosion.

Straight, Two-Pass and U-Bent elements are furnished with mounting flanges, making them individually removable through the terminal box.

# Specific Requirements

**Safety** – Because the heating coil is completely encased in a grounded metal sheath, shock hazard due to accidental contact with the coil is eliminated. Heaters installed close to a register, grille, or access door should either use finned tubular construction or an open coil unit with a protective screen.

**Airflow Contamination** – If airborne contamination, such as dirt or dust, builds up on open coil elements during shutdown periods, the elements can short out. Finned tubular elements, with their insulated coils, eliminate this problem. Furthermore, upon start-up, a finned tubular heater which has been exposed to droplets of water in the airstream (e.g. immediately downstream from a spray type humidifier, a cooling coil, or a fresh air intake) cannot short to ground as open coils can when support bushings are wet.

**Serviceability** – In the unlikely event of element failure, it is easier to replace individually mounted finned tubular elements than open coil elements.

**Mechanical Stability** – Finned tubular elements are more rugged than open coils. They will withstand more physical abuse.

**Airflow Uniformity** – Finned tubular duct heaters tend to be more tolerant of nonuniform airflow conditions. Heat conducted along the element length reduces or eliminates hot spots resulting from nonuniform airflow. With open coil heaters, it may be necessary to use a pressure plate to compensate for bad airflow conditions.

**Controllability** – Because of their relatively high thermal inertia, finned tubular elements controlled with on/off thermostat systems provide more precise control. Furthermore, finned tubular elements cycle at a reduced rate, thus increasing the life of the power components such as contactors. Nevertheless, when SCR controllers are used, equally precise control can be obtained with either construction.

## Calculating KW Requirements

Once the volume of airflow (CFM – in cubic feet per minute) and the required temperature rise ( $\Delta T$  – in degrees F) through the heater are known, the required kilowatt rating (KW) of the heater can be determined from the formula:

$$KW = \frac{CFM \times \Delta T^{\circ}F}{3193} \quad KW = \left( \frac{\text{Liters/Second} \times \Delta T^{\circ}C}{837} \right)$$

Where the desired heating capacity in BTU/Hr is known, the KW is determined from the following formula:

$$KW = \frac{BTU/Hr}{3412}$$

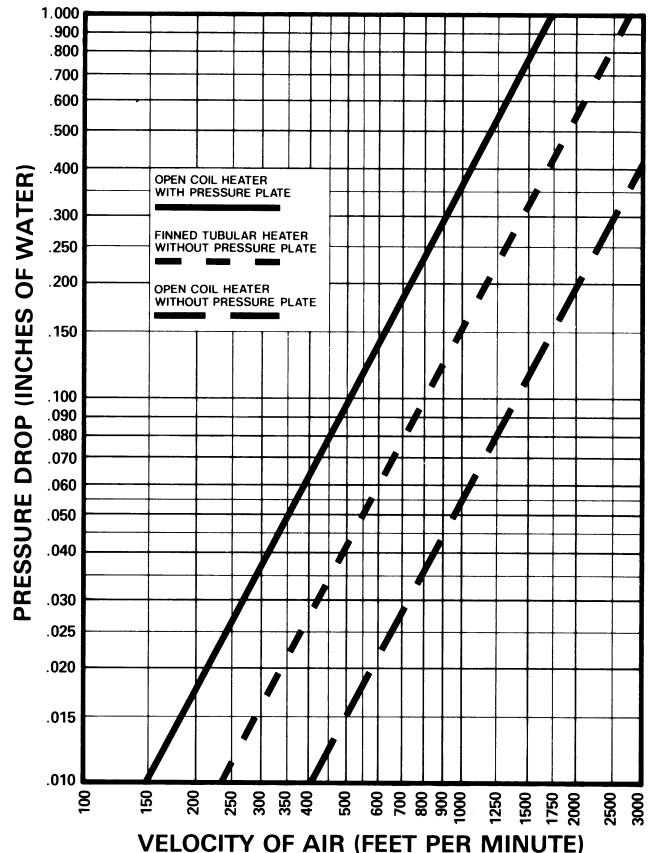

Figure 3.

## Static Pressure Drop

Static pressure drop through an open coil heater is quite low and, in most cases, can be ignored when calculating system pressure drop. The pressure drop across a finned tubular heater is greater than across an open coil.

However, if pressure plates must be added to an open coil, the pressure drop over the open coil far exceeds the drop over a finned tubular heater. The curves in Figure 3 give data for all three constructions.

# Specific Requirements

## Minimum Velocity

Electric heaters differ from steam or hot water coils in that the heat output is constant as long as the heater is energized. Therefore, sufficient airflow must be provided to prevent overheating and nuisance tripping of the thermal cutouts. The minimum required velocity is determined from Figure 4A or 4B on the basis of entering air temperature and KW per square foot of cross sectional duct area.

The maximum air inlet temperature for open coil heaters is 100°F (38°C) and for finned tubular heaters is 80°F (27°C).

Example: Determine whether the minimum air velocity requirement is met for a 10 KW open coil heater installed in a 24" wide x 12" high duct operating with 1000 cubic feet per minute (CFM) of air at a maximum inlet temperature of 65°F:

1. Duct Area = 24" x 12"/144 = 2 sq. ft.
2. KW per square foot = 10 KW/2 sq. ft. = 5.
3. Go to Figure 4B. Use top curve (below 80°F inlet air). Find 5 KW per square foot on the vertical axis. Read minimum velocity required, which in this case is 310 feet per minute (FPM).
4. Heater air velocity = 1000 CFM/2 sq.ft. = 500FPM. Since 500 FPM exceeds the minimum, this installation is safe. Consult your local Indeeco representative for assistance if you do not have sufficient air velocity.

## Maximum Velocity

High velocity airflow is not normally encountered in typical commercial HVAC applications, when installing open coil duct heaters into velocities over 1200 feet per minute contact your local Indeeco representative.

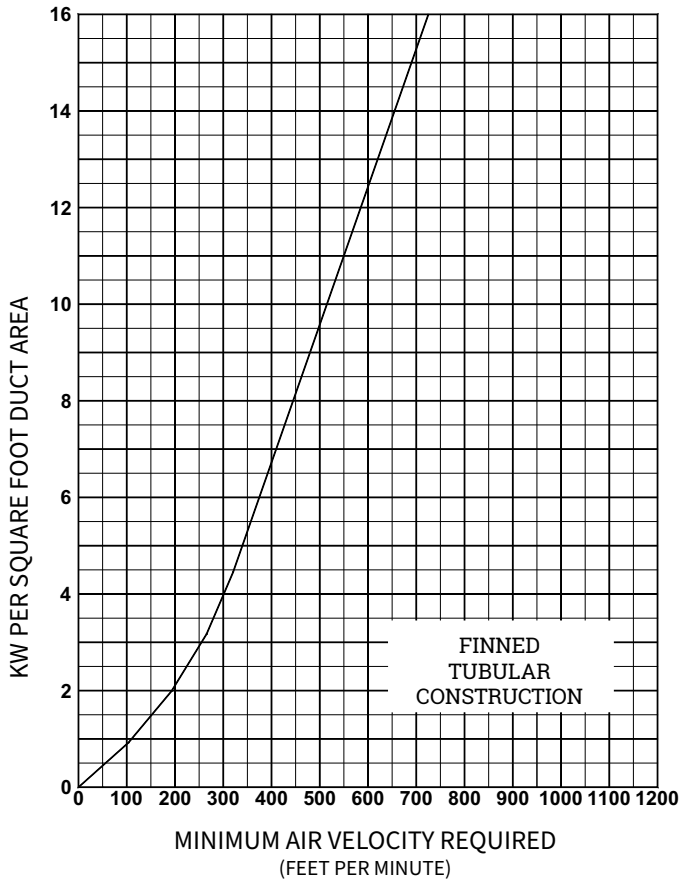

Figure 4A.

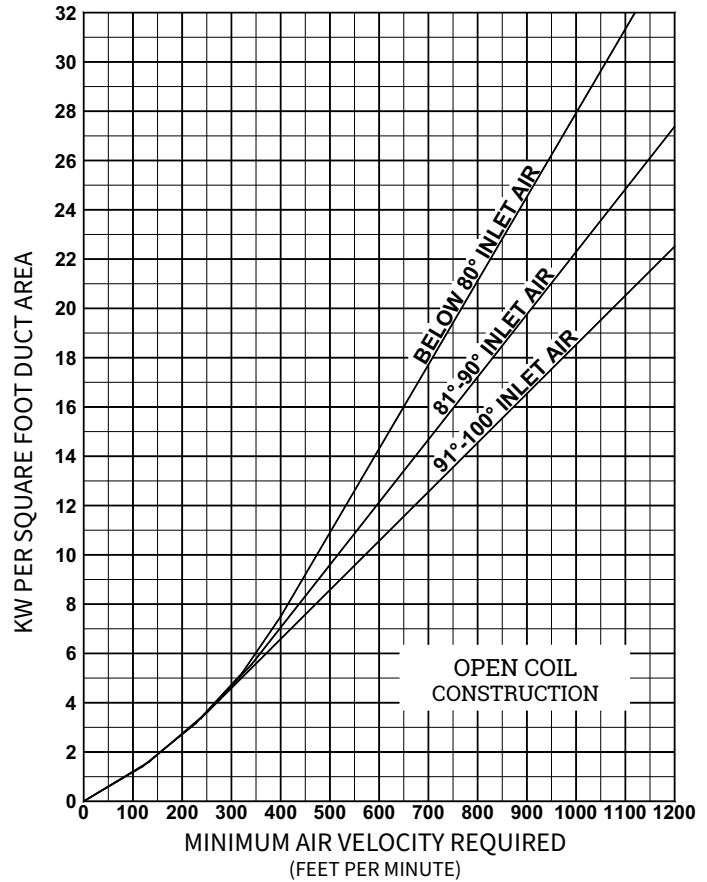

Figure 4B.

# Specific Requirements

## Airflow Uniformity

To prevent hot spots, airflow must be uniformly distributed across the heater face. Figure 5 illustrates typical heater misapplications which result in non-uniform airflow. The heater's UL Listing requires that it not be installed closer than 4' (122 cm) downstream or upstream from a fan outlet, abrupt transition, or other obstructions. Elbows or turns must be located at least 4' (122 cm) from inlet of the heater and 2' (61 cm) from outlet of the heater.

If such an installation cannot be avoided, consult your local Indeeco representative for assistance. We can provide a pressure plate, non-heated zones or special low watt density coils to overcome these problems. Final approval of such applications is up to the local inspection authority.

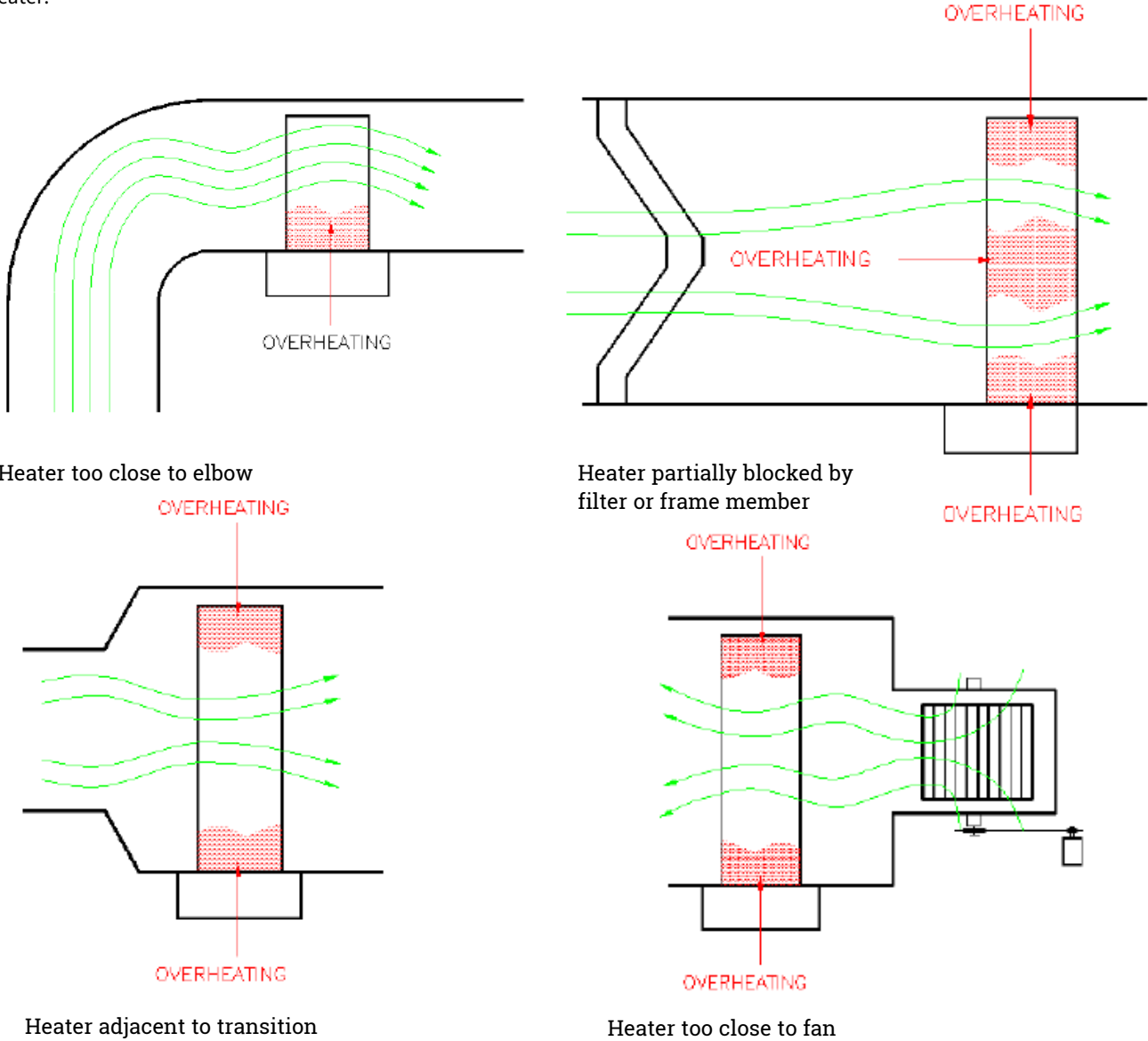

Figure 5.

# Specific Requirements

## Multiple Heaters in the Duct

Indeeco heaters are not designed for series installation in a single duct. Since Indeeco heaters can be furnished in virtually any size and KW rating, series installation of heaters can be avoided.

For very large heaters, field installation and shipping may be simplified by using two or more sections as illustrated by Figure 6. Each section, furnished in the flanged design, has its own set of thermal limit controls. Terminal blocks are provided to interconnect these cutouts in the field. Sections rest stably one on top of the other.

Heaters more than 6' (152 cm) high are normally provided in sections, but larger single section heaters can be provided. Consult your local Indeeco representative for details.

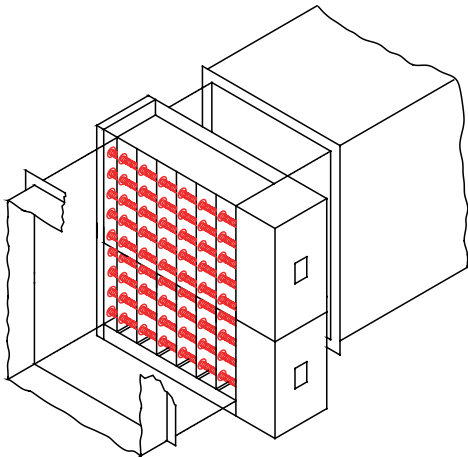

Figure 6.

## Clearance

Indeeco heaters are UL Listed for zero clearance to combustible surfaces. Thus, there is no minimum distance between combustible materials and the section of duct housing the heater, or the heater itself. However, the terminal box must be accessible for servicing. The NEC requires a minimum workspace at least 30" (76 cm) wide by 42" (107 cm) deep for access to the heater terminal box. More space is required for large heaters and for removal of slip-in heaters which are over 42" long.

In addition, sufficient clearance must be provided for convection cooling of all heaters with built-in SCR power controllers (Figure 7). Allow at least 5" (12.7 cm) of free air space around the cooling fins extending from the heater terminal box. Enclosing the fins in any fashion, insulating them, or preventing them from being cooled by normal convection may cause controller failure and void the heater warranty.

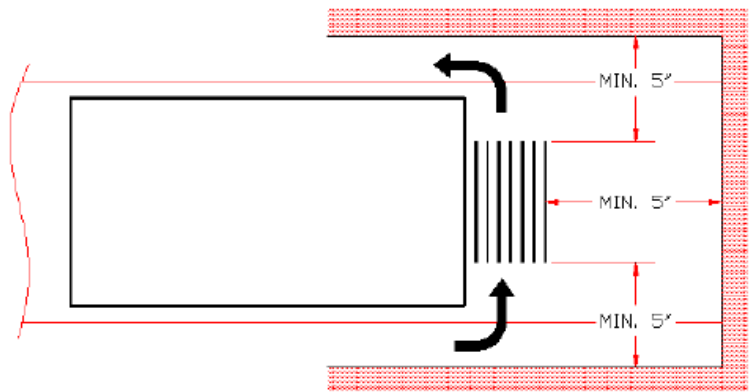

Figure 7.

# Specific Requirements

## UL and NEC Requirements

All Indeeco electric duct heaters described in this catalog meet the requirements of Underwriters Laboratories (UL) and the National Electrical Code (NEC) unless otherwise indicated.†

Heaters furnished with one of the Control Options on pages 10 and 11 are automatically UL Listed and meet NEC requirements. Custom designed heaters must meet certain requirements to comply with UL and the NEC. The areas of particular concern are outlined below.

**Overtemperature Protection** – Duct heaters must be supplied with both primary and secondary overtemperature protection. All Indeeco heaters are provided with both automatic and manual reset thermal cutouts to serve this function.

**Airflow Interlocks** – An airflow interlock must be provided to keep the heater from operating with extremely low or no airflow. Indeeco's standard, a built-in differential pressure airflow switch described on page 15, senses static pressure in the duct as an indicator of airflow. Separate wiring to the fan motor or its controls is unnecessary.

Alternative methods for detecting airflow include:

1. The fan relay, described on page 15, provides a positive electrical interlock with the fan circuit.
2. A separate contactor, built into the duct heater, can energize the fan when the duct heater is on.
3. A terminal block to allow field connection of external contacts that close the circuit only when the fan is operating.

**Contactors** – Contactors connected to the primary thermal cutout and airflow interlock safety circuits must be provided by the duct heater manufacturer. Effective June 2009 UL requires that all open coil element duct heaters be furnished with disconnecting type controlling, safety and backup contactors breaking all ungrounded conductors. Practically speaking, this

means that all, but small 120 and 277 volt single-phase open coil heaters, must be supplied with either disconnecting contactors built into the heater terminal box or into a remote panelboard. Indeeco's standard is to supply disconnecting contactors which break all ungrounded conductors in open coil heaters. Due to the intrinsic safety of finned tubular duct heaters, UL does not require the use of disconnecting type contactors. Indeeco's standard is to supply de-energizing contactors, which break only one line of single-phase circuits and two lines of three-phase circuits. Disconnecting contactors are available with finned tubular heaters if required.

**Overcurrent Protection** – For heaters drawing more than 48 amps, the duct heater manufacturer must provide some means of overcurrent protection either built into the terminal box or a remote panelboard. While fuses or circuit breakers are available to meet this requirement, Indeeco's standard is fuses.

**Disconnecting Means** – All duct heater installations require a disconnecting means at or within sight of the heater controls. We recommend that a built-in, snap-acting, door interlocking disconnect switch with marked "on" and "off" positions with lock-out tag-out feature be specified on all duct heaters. This insures the ultimate in safety, since the heater and built-in controls cannot be serviced without turning the disconnect switch off. It is also far less expensive than one obtained and installed in the field.

## International Requirements

Indeeco heaters can be supplied to operate from any electrical system throughout the world. Single and three-phase voltages through 600 volts are available. As described on pages 24 through 31, all type QUA and QUZ standard heaters are available in 380, 400 or 415 volt, three-phase ratings. All Indeeco heaters will operate on either 50 or 60 Hz.

Indeeco electric duct heaters are available with Canadian Standards Association (CSA) and Canadian Electric Code (CEC) approvals. Consult your Indeeco representative for information and availability.

† Although UL requirements are uniform throughout the country, local electrical codes may deviate from the NEC. For information on local requirements, consult your Indeeco representative.



# Installation Information

## Heater Installation

Slip-in heaters slide through a rectangular opening in the side of the duct per Figure 8. The heater is designed for 1/4" (6.35 mm) clearance around the inside of the duct. Slip-in construction is normally preferred for ducts up to 4' (122 cm) wide, but can be furnished for any width. The heaters are held in place with sheet metal screws through the back of the terminal box into the duct. However, if the duct is over 3' (91 cm) wide, supporting rails in the bottom of the duct are recommended.

Flanged heaters are attached to matching external duct flanges per Figure 9. The heaters are secured by using either sheet metal screws or bolts and nuts through the flanges.

A special flanged construction installed with conventional HVAC slip-and-drive connectors is also available. See page 37 for details.

Either flanged or slip-in heaters can be installed in fiberglass ducts as illustrated in Figure 10. Note that a sheet metal liner must be installed into the fiberglass duct work, extending at least 6" (152 mm) beyond the heater terminal box on both sides, more if required for structural rigidity.

## Field Wiring

Built-in power terminal blocks are sized for incoming copper conductors with 75°C insulation, rated to carry 125% of the heater load. However, lines may be sized to carry 100% of the heater load if a) the heater is rated at 50 KW or more, and b) the heater is controlled by a cycling device, such as a multi-staged thermostat, step controller, or SCR power controller. Terminal blocks and knockouts on such heaters will accommodate either 100% or 125% conductors. See **Table I** for field conductor and conduit sizing up to 500 MCM wiring. For higher amperages, terminal blocks are furnished for two or more parallel conductors per phase.

In general, aluminum conductors are not recommended and terminal blocks are not sized for aluminum. Consult your Indeeco representative if aluminum wire is specified for a particular job.

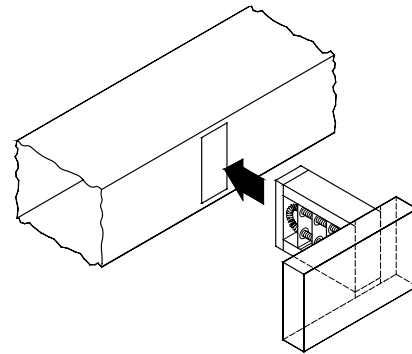

Figure 8.

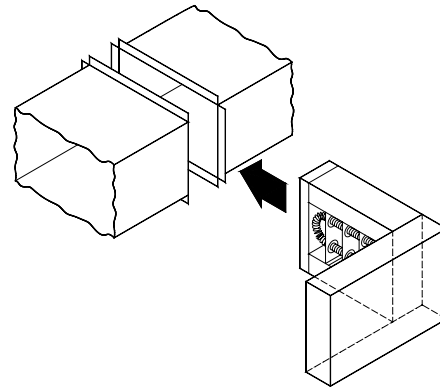

Figure 9.

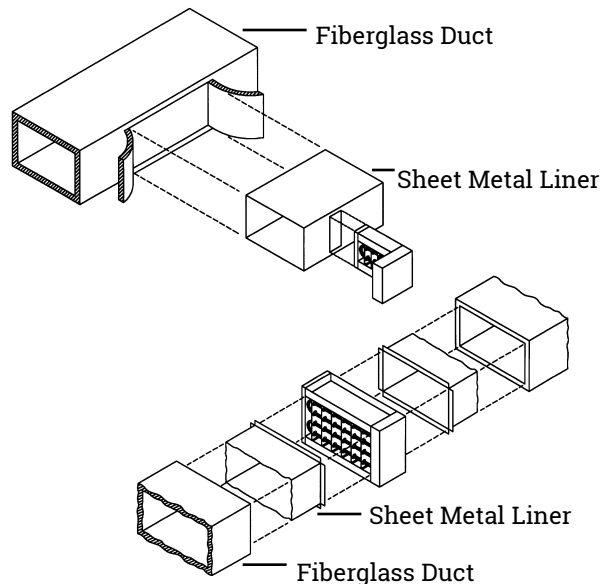

Figure 10.

# Installation Information

Field control wiring should also be copper conductors with 75°C insulation. Thermostat circuits for SCR's and step controllers are NEC Class II. Many small heaters with 24 volt control circuits are also NEC Class II. When Class II wiring is permissible, it will be shown on the wiring schematic. Other control circuits are NEC Class I.

When control power is taken from the heater's load circuit lines, Indeeco provides for the overcurrent protection of all control circuits, as required by NEC or UL. When control circuit power is obtained from a separate source outside the heater, it is necessary for the installer to provide overcurrent protection for all control conductors.

**Table I**  
**Field Wiring and Conduit Sizing\* for Incoming Conductors**

	KW in Voltages Shown							Wire/ Size AWG or MCM	Trade Conduit Size (Inches)		Load Amps
	Single-Phase				Three-Phase				1Ø	3Ø	
	120V	208V	240V	277V	208V	240V	480V				
<b>Sized for 125% of Heater Load</b>	1.4	2.4	2.8	3.3	4.3	4.9	9.9	14	1/2	1/2	12
	1.9	3.3	3.8	4.4	5.7	6.6	13.3	12	1/2	1/2	16
	2.8	4.9	5.7	6.6	8.6	9.9	19.9	10	1/2	3/4	24
	4.8	8.3	9.6	11.0	14.4	16.6	33.2	8	3/4	1	40
	6.2	10.8	12.4	14.4	18.7	21.6	43.2	6	1	1	52
	8.1	14.1	16.3	18.8	24.4	28.2	56.5	4	1	1-1/4	68
	9.6	16.6	19.2	22.1	28.8	33.2	66.5	3	1	1-1/4	80
	11.0	19.1	22.0	25.4	33.1	38.2	76.4	2	1-1/4	1-1/4	92
	12.4	21.6	24.9	28.8	37.4	43.2	86.4	1	1-1/4	1-1/2	104
	14.4	24.9	28.8	33.2	43.2	49.8	99.7	1/0	1-1/4	1-1/2	120
	16.8	29.1	33.6	38.7	50.4	58.1	116.3	2/0	1-1/2	2	140
	19.2	33.2	38.4	44.3	57.6	66.5	133.0	3/0	1-1/2	2	160
	22.0	38.2	44.1	50.9	66.2	76.4	152.9	4/0	2	2-1/2	184
	24.4	42.4	48.9	56.5	73.4	84.8	169.6	250	2	2-1/2	204
	27.4	47.4	54.7	63.2	82.1	94.7	189.5	300	2	3	228
	29.8	51.6	59.5	68.7	89.3	103.0	206.1	350	2-1/2	3	248
	32.2	55.7	64.3	74.2	96.5	111.4	222.8	400	2-1/2	3	268
	36.5	63.2	73.0	84.2	109.5	126.3	252.7	500	2-1/2	3	304
<b>Sized For 100% of Heater Load</b>						54.0	6	1	1	65	
						70.7	4	1	1	85	
						83.1	3	1	1-1/4	100	
						95.6	2	1-1/4	1-1/4	115	
					54.0	108.1	1	1-1/4	1-1/2	130	
					54.0	62.4	124.7	1/0	1-1/4	1-1/2	150
					63.0	72.7	145.5	2/0	1-1/2	2	175
				55.4	72.1	83.1	166.3	3/0	1-1/2	2	200
			55.2	63.7	82.9	95.6	191.2	4/0	2	2	230
		53.0	61.2	70.6	91.9	106.0	212.0	250	2	2-1/2	255
		59.2	68.4	78.9	102.6	118.4	236.9	300	2	2-1/2	285
		64.5	74.4	85.9	111.7	128.9	257.7	350	2-1/2	3	310
		69.7	80.4	92.8	120.7	139.2	278.5	400	2-1/2	3	335
		79.0	91.2	105.3	136.9	158.0	315.9	500	2-1/2	3	380

\*These tabulations are based on Table 310.15 (B) (16) of the NEC. Not more than 3 conductors in a raceway; 75°C rated copper wire.

# Standard Control Options

## Internal Wiring

Copper wire with a minimum of 105°C insulation is used throughout. Connections are made with either box lugs or connectors crimped on with calibrated tooling. Terminal blocks are provided for all field control and power wiring.

Indeeco developed the Control Option concept to maintain compliance with changing UL and NEC requirements and to stay current with new duct heater temperature control systems. The concept has also been broadened to include numerous “Special Features” to meet a wide variety of special requirements.

## Control Option G – Basic

Control Option G is a basic package designed for normal comfort heating applications – i.e., those that do not require pneumatic control or the unique features of SCR control. With Option G, the temperature is controlled by a pilot duty thermostat or a step controller.

Control Option G includes the following:

- **Automatic and manual reset thermal cutouts** to protect against overheating. The automatic reset cutout is wired into the control circuit; the manual reset de-energizes the heater load.
- A differential pressure **airflow switch** to de-energize the heater control circuit upon loss of airflow.
- **Magnetic contactors** for each heater stage.
- **Fuses** to protect each circuit in any heater drawing more than 48 amps.
- A control circuit **transformer**, with 24 or 120 volt secondary as specified, including any overcurrent protection required by UL or the NEC.
- A built-in, snap-acting **disconnect switch** with door interlock to protect service personnel.

## Control Option J – Pneumatic

Control Option J is designed for pneumatic temperature control.† The contractor need only connect one air line and the main power lines to the heater.

Option J includes the following:

- **Automatic and manual reset thermal cutouts** and a differential pressure **airflow switch**. The manual reset thermal cutouts always de-energize the heater load. The automatic reset cutout and airflow switch are normally wired in the control circuit.
- **PE switches** to control heater staging. To minimize field labor, multiple PE switches are factory-piped to a single port projecting through the terminal box. All PE switches close on pressure rise and open upon loss of pressure to de-energize the heater.
- **Magnetic contactors** on all Option J heaters.
- **Fuses** to protect each circuit in any heater drawing more than 48 amps.
- A **transformer**, with any overcurrent protection required by UL or the NEC, to supply the internal control circuit of heaters rated above 277 volts. All other heaters have line voltage control circuits.
- A built-in, snap-acting **disconnect switch** with door interlock to protect service personnel.

† Where more than six stages of pneumatic control are required, specify Option G with a step controller and pneumatic transducer as Special Features. Such a heater will function in the same manner as Option J with a maximum of 20 stages.

# Standard Control Options

## Control Option K – Proportional

Control Option K is designed for the most precise temperature control, using SCR proportional power controllers and a matching electronic thermostat. For heaters above the KW ratings in **Table III**, an electronic step controller is also provided. It works with the SCR to provide vernier proportional control. For more details on this system, see page 20.

**Table III**

Voltage		120	208	240	277	480	600
Maximum KW	1 Phase	23.0	39.9	46.0	53.1	91.1	115.2
	3 Phase	—	34.5	39.9	—	79.8	99.7

In addition to these electronic components, Control Option K includes the following:

- **Automatic and manual reset thermal cutouts** and a differential **pressure airflow** switch. The manual reset thermal cutouts always de-energize the heater load. The automatic cutout and airflow switch are normally wired in the control circuit. However, when single-phase KW ratings do not exceed the values in **Table IV**, the automatic reset cutout carries the heater load directly and the airflow switch either carries the load directly or is wired into the control circuit of the SCR, eliminating the need for magnetic contactors.
- **Safety magnetic contactors** controlled by the automatic reset cutout, for each heater circuit, when the KW exceeds the ratings in **Table IV**.

**Table IV**

Open Coil Heaters				
Single-Phase Voltage	120	208	240	277
Maximum KW	3.0	—	—	6.0
Finned Tubular Heaters				
Maximum KW	3.0	5.2	6.0	6.0

- **Magnetic contactors** for each heater circuit.
- **Fuses** to protect each circuit in any heater drawing more than 48 amps.
- A **transformer**, with any overcurrent protection required by UL or the NEC, to supply the internal control circuit of 24 or 120 volts per heater with a step controller for vernier control and 24 volts for all other heaters with SCR control. Wiring to remotely mounted thermostats can be Class II since thermostat circuits are low voltage limited power circuits.
- A built-in, snap-acting **disconnect switch** with door interlock to protect service personnel.
- A choice of room thermostat, page 12, Figure 15 or 16; duct thermostat, page 13, Figure 20 or 21; built-in PE transducer, page 13, Figure 17; or field inputs of 135 ohms, 2200 ohms, 0-10 VDC and 4-20mA are available.

## Wiring Diagrams

Typical wiring diagrams for many of the commonly used control options are located on pages 56 – 58. These diagrams of open coil and finned tubular heater constructions are intended to provide general component arrangements and wiring information. Specific wiring diagrams will be attached to the inside of the enclosure doors for each heater and remote panelboard and are available with certified prints.

# Standard Control Options Thermostats

## Room Thermostats

### Single Stage, Catalog No. 1006998

- Non-digital, non-programmable, snap-acting bimetal, mercury free, SPST, with positive off single stage
- Range: 50° to 90°F (7° to 32°C)
- Accuracy: ±3°F (±1.5°C)
- Color: White
- Inductive Rating: 1.2 amp at 30 volts max
- Offered with duct heater selection



Figure 11.

### Single Stage, Catalog No. 1023721

- Digital, with programmable 5-1-1 day program or 5-2 day program, mercury free
- HEAT-OFF-COOL-AUTO-EM and fan AUTO-ON selections - CIRC- follow schedule
- Easy to read backlit display
- Range: 40° to 90°F (4.5° to 32°C)
- Accuracy: ±1°F (±0.5°C)
- Color: White
- Inductive Rating: Hardwire, two wire heat only Class II circuit, 1.0 amp at 30 volts max
- Special Order



Figure 12.

### Two Stage, Catalog No. 1007030

- Digital, non-programmable, mercury free
- COOL-HEAT-OFF EMERGENCY HEAT and fan AUTO-ON selections
- Easy to read backlit display
- Range: 40° to 90°F (4.5° to 32°C)
- Accuracy: ±1°F (±0.5°C)
- Color: White
- Inductive Rating: Hardwire, three wire heat only Class II circuit, 1.0 amp at 30 volts max



Figure 13.

### Two or Three Stage, Catalog No. 1023723

- Digital, with programmable 5-1-1 day program or 5-2 day program, mercury free
- HEAT-OFF-COOL-AUTO EMERGENCY HEAT and fan AUTO-ON - CIRC- follow schedule selections
- Easy to read backlit display
- Range: 40° to 90°F (4.5° to 32°C)
- Accuracy: ±1°F (±0.5°C)
- Color: White
- Inductive Rating: Hardwire, three or four wire heat only Class II circuit, 1.0 amp at 30 volts max



Figure 14.

### Electronic Thermostat, Catalog No. 1031404

- TA167 Thermostat is proportional 1-10 VDC
- Range: 50° to 90°F
- For use with Indeeco controllers



Figure 15.

## PE Transducer

### Catalog No. 1020887

- Built into heater terminal box
- PSIG range: 0 to 15
- Throttling range: 1 – 12 psi
- Maximum pressure: 25 psi
- Type: Ohmic – 135 ohms
- For use with Indeeco SCR's and step controllers



Figure 16.

# Standard Control Options Thermostats

## Duct Thermostats

### Single Stage Heavy Duty, Catalog No. 1023953

- Liquid filled sensing element with snap-acting contacts
- Range: -30° to 100°F
- Differential: 3 to 12°F between stages
- Bulb Dimensions: 3/8" x 4"
- Capillary Length: 8'
- Resistive Rating: 22 amps, 120 to 277 volts



Figure 17.

### Two Stage Light Duty, Catalog No. 1007044

- Two single-pole, double throw switches
- Adjustable by screw on graduated cam dial
- Range: 55° to 85°F
- Differential: 2°F between stages
- Bulb Dimensions: 5/8" x 11<sup>11</sup>/<sub>16</sub>"
- Capillary Length: 5'6"
- Resistive Rating per Heater Stage:
  - 3.2 amps at 120 volts
  - 1.6 amps at 240 volts



Figure 18.

### Electronic Proportional

Catalog No.: Sensor, 1001083

Adjuster, 1001068

- Range: 60° to 120°F
- Type: Ohmic – 2200 ohms
- For use with Indeco controllers

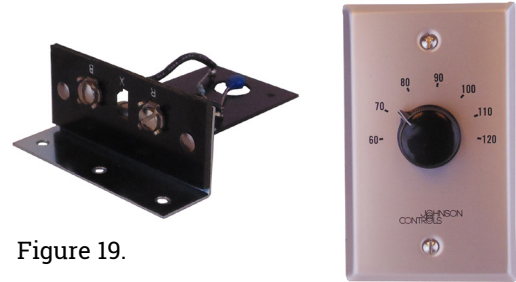

Figure 19.

### Electronic Thermostat

Catalog No.: Sensor, 1031407

Adjuster, 1031404

- Range: 50° to 90°F
- Type: Proportional 0-10 VDC
- For use with Indeco controller



Figure 20.

# Construction Electrical

Indeeco offers a broad range of electrical components for temperature, safety, and power control.

For most applications, the Control Option system, described in the previous section, makes it easy to specify a complete control package.

For applications requiring a special control system, the following section describes components, their applications, and limitations.

## Bi-Metallic Thermal Cutouts

Both UL and NEC require thermal cutout protection against overheating due to insufficient airflow, air blockage or air failure. Two levels of protection are provided:



Figure 22.

The primary or automatic reset thermal cutout (Figure 22) is a fixed temperature, bi-metallic disc type device which opens when its set point is reached and automatically resets when the temperature falls below its set point. The operating disc and contacts are completely enclosed to prevent infiltration of dirt or physical damage. This single pole device is most often wired into the heater control circuit, but will carry single-phase loads up to 25 amps at 240 volts and 22 amps at 277 volts (See **Table V**). Most heaters have only one automatic reset thermal cutout. However, on large heaters, two or more may be supplied, wired in series.

Table V

Single-Phase Voltage	120	208	240	277
Maximum KW	3.0	5.2	6.0	6.0

The secondary manual reset thermal cutout (Figure 23) has a temperature setting approximately 50°F (28°C) higher than the automatic reset cutout to provide protection only if the primary system fails. Once it has tripped, it is necessary to press a reset tab to return the heater to operation.



Figure 23.

Open coil heaters use a cutout rated to carry the maximum heater circuit load allowed by UL and NEC: 48 amps at 480 volts. One cutout is supplied for each heater circuit, or group of circuits, drawing 48 amps or less.

Many manufacturers use heat limiters or fusible links which require field replacement when an overtemperature condition occurs. This often involves removing the heater from the duct and always involves ordering replacement heat limiters from the manufacturer. With Indeeco's manual resets, the heater can immediately be put back into operation, simply by pressing the reset button.

There is no danger that backup protection will be lost because replacement heat limiters are not available. Furthermore, the services of a qualified electrician are not required, since maintenance personnel can easily reset the manual cutouts.

## Linear Thermal Cutouts



Figure 24.

The linear thermal cutouts (both automatic and manual reset) sensing element (Figure 24) is a fluid-filled capillary tube, strung across the entire heater width. If any 6" (152 mm) segment of the capillary is overheated, the cutout will de-energize the entire heater, providing additional protection if the airflow is

# Construction Electrical

not sufficiently uniform. Furthermore, it is fail safe – it will trip if the capillary loses its fill. These cutouts are normally provided for pilot duty but can carry a single phase heater load directly up to 20 amps, 277 volts.

**Custom open coil heaters** – Only one linear automatic and/or one linear manual, set 50°F (10°C) higher than the automatic, may be furnished, in addition to the standard cutouts. They are wired in series with the standard disc type automatic cutout.

**Finned tubular heaters** – Three levels of over temperature protection are standard for finned tubular heaters. In addition to the automatic disc thermal cutout, Figure 22, both automatic and manual reset linear cutouts, Figure 24, are furnished.

An automatic primary linear limit cutout, strung across the top and leaving air face of the coil (Figure 25), protects against overheating caused by low airflow. This device will turn the heater off if the fixed temperature set point is exceeded. It automatically resets when the temperature drops to safe levels.

Figure 25

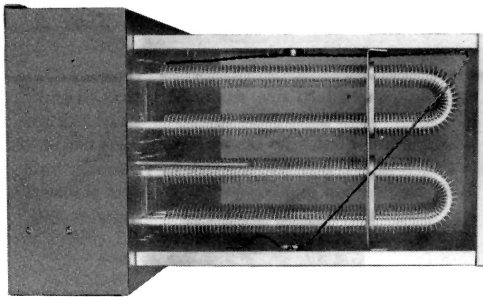

A manual secondary linear limit cutout protects against failure of the primary overtemperature system. With a fixed temperature setting higher than either of the primary cutouts described above, this device is designed to trip only if both of the primary cutouts stick in the closed position, or controlling contactor points weld together.

## Airflow Switch

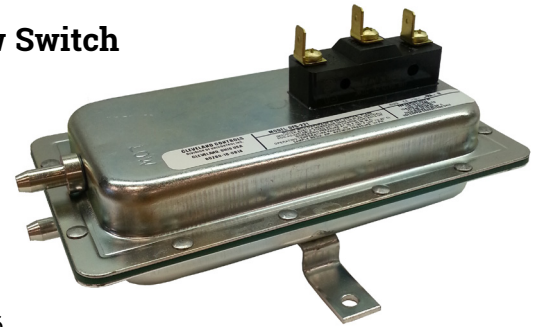

Figure 26.

A diaphragm operated differential pressure switch (Figure 26) is normally used to prevent a heater from operating unless air is flowing. The switch is provided with a velocity pick-up tube extending into the duct area, making it sensitive to static pressure as well as velocity pressure.

The switch requires at least .07" (17.4 Pa) of water column pressure difference between the inside and the outside of the duct. If the pressure is below .07", a fan relay should be substituted as described below.

Airflow switches are normally connected for positive pressure – i.e. for a heater located on the discharge side of a fan. If the heater is on the suction side, the switch may be specified or field converted for negative pressure. In most applications the airflow switch is wired into the heater control circuit, but it can carry the heater load directly up to 15 amps at 277 volts, single-phase.

## Fan Relay

Figure 27

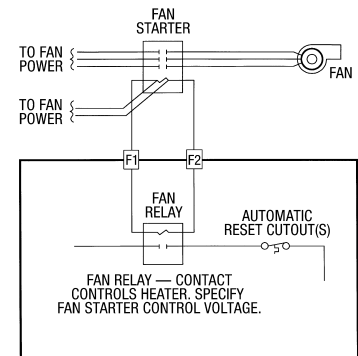

A fan relay is available as an alternate to the standard airflow switch. It has the advantage of being a positive electrical interlock between the fan and the heater (see Figure 27 for wiring details). Its primary disadvantages are that it requires field wiring back to the fan control circuit and does not protect against conditions such as belt failure. When a fan relay is required, specify the fan starter control voltage. If not specified, it will be assumed to be the same as the heater control voltage. Both a fan relay and an airflow switch can be furnished.



# Construction Electrical

## Magnetic Contactors



Figure 28

All magnetic contactors supplied by Indeeco are UL Recognized for limit control duty, as opposed to less severe, general purpose duty. De-energizing contactors, break one power line on single-phase circuits and two lines on three-phase. Disconnecting contactors, break all ungrounded conductors, one power line on 120 and 277 volt single-phase, two power lines on 208 and 240 volt single-phase and all lines on three-phase. Both de-energizing and disconnecting contactors are available with ratings up to 600 volts. Contactors are available with holding coil voltages of 24, 120, 208, 240 or 277.

## Control Transformer



Figure 30

Built-in control transformers are available to supply either 24 or 120 volt control circuits. The transformer primary is factory connected to the main supply and the secondary is wired directly to the built-in control components. Overcurrent protection and secondary grounding are provided when required by UL and the NEC.

## Disconnect Switch



Figure 31.

Built-in disconnect switches are an inexpensive, positive way to meet the NEC requirement for a disconnecting means within sight of the heater, controller(s), and overcurrent protection devices. The switches are interlocked with the heater terminal box cover and have labeled “on” and “off” positions. If there are any external sources of control voltage, a separate toggle switch is provided. Together these devices result in a “dead front” design to protect service personnel. Both fused (up to 48 amps) and unfused switches are available. However, unfused switches are most often specified, as they meet code safety requirements.

## Fuses



Figure 29

Low resistance fuses are mounted in phenolic fuse blocks fitted with extra tension springs to assure cool connections. To protect against faults in both contactors and heating elements, fuses are located on the line side of contactors built into heaters. To meet NEC requirements for continuous loads, fuses are rated at least 25% above the load they are protecting.

## Pilot Lights



Figure 32.

Pilot lights, projecting through the side of the heater terminal box, indicate functional operation. The most commonly specified functions are:

**Heater On** – This indicates that power has been supplied to the heater, but does not necessarily indicate that the control system is calling for heat or that heat is being produced.

**Low Airflow** – This indicates that there is either no airflow, or it is so low that the airflow switch has prevented the heater from operating.

**Each Stage On** – These indicate when each heater stage has been energized. Not available with SCR controlled stages.

**Overtemperature** – This indicates when the automatic reset thermal cutout has tripped due to an overtemperature condition. Only available with custom heaters.

## Pilot Switch

A pilot switch is a simple means of de-energizing the heater between seasons or during prolonged shut-downs. The switch is wired in series with contactor holding coils. It cannot be used as a disconnecting means and is therefore labeled with “on” and “standby” positions. If disconnecting contactors are also specified, the switch will have a labeled “off” position in accordance with UL and NEC provisions.

## Pneumatic/Electric (PE) Switches



Figure 33.

Built-in and pre-wired PE switches are available for pneumatic control systems. To minimize field labor, all PE switches are factory piped to a single port projecting through the terminal box. Pneumatic connections may, therefore, be made without interfering with electrical connections. Standard switches close on pressure rise, resulting in a fail-safe system since a loss of pressure de-energizes the heater. “Open on rise” switches are available on custom heaters for special applications.

PE switches can either be used as pilot duty devices, or to carry heater loads up to 22 amps, 480 volts, single-phase.

PE switches are limited to six stages, because it is difficult to calibrate more switches and still maintain proper staging. For more than six stages, specify a step controller (described on pages 19 and 20) with a pneumatic transducer (described on page 13).

# Construction Electrical

## Electronic Controls

Indeeco designs and manufactures the electronic controls supplied with Indeeco duct heaters. Controllers manufactured by Indeeco have a proven track record of reliability and performance. For custom control application requirements, please contact factory for design options.

Indeeco duct heaters may be specified with either SCR power controllers or electronic step controllers. While inherently different, these devices have certain common characteristics:

- Safety – All Indeeco electronic control devices are UL Recognized and evaluated for use as a component of Indeeco duct heaters.
- Input Flexibility - While normally supplied with a room thermostat, these devices can interface with many field supplied ohmic sensors or electronically generated control signals, such as proportional mA or DC voltages.
- Low Voltage Control – NEC Class II field wiring may be used for the input control signal circuits of all devices.
- High Ambient Temperature Rating – All units are designed for full load operation in high ambient temperatures, making them particularly suitable for use in duct heater and remote panel applications.
- Fail Safe Circuitry – In the event of either a short or open circuit in the input signal leads, all controls de-energize the heaters in order to prevent runaway overheating conditions.
- LED Indicators – LED pilot lights are provided on all controls. For SCR power controllers, the LED is provided to give indication of percentage power output being supplied to the heater. On step controllers, LED indicators are used to convey both operating status and troubleshooting information.
- Continuous Feedback – Logic and control circuits continuously monitor the input signal to provide precise temperature control.

SCR power controllers are provided in many different configurations to support applications in indoor, outdoor and dusty environments. Field selectable inputs are provided to support 4-20 mA, 0-10 VDC, 135 ohm and 2200 ohm signals.

## SCR Power Controllers

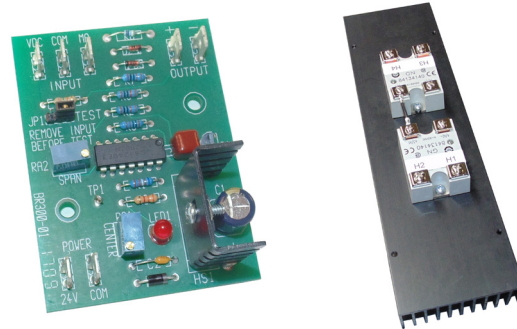

Figure 34. 108 Series for indoor use

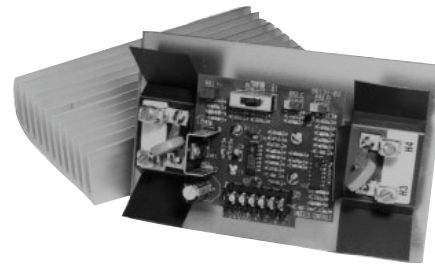

Figure 35. Series 103 for outdoor and dusty applications

SCR power controllers modulate the entire heater load between 0-100%. Working on a one second time base, the heater will only be energized for the number of AC cycles necessary to produce the exact required amount of heater resulting in very precise temperature control using the least amount of energy. The resulting precision and rapid response make the Indeeco SCR the preferred choice for many heating applications.

The SCR relays are mounted to a finned heat sink which extends outside the heater terminal box or control panel. The heat sink has been specifically designed for maximum heat dissipation. The combination of a conservative SCR rating (no more than 75% of the relay manufacturer's rating) and an efficiently designed heat sink ensure a long component life by protecting against overheating and SCR failure.

Both single and three phase SCR controllers are available in a master or slave configuration. Each master is capable of driving up to three slaves, giving maximum capability for 100%, fully proportional SCR control. However, when the load exceeds that tabulated in Table III on page 11, it is more economical to utilize

an Indeeco step controller with a slave SCR wired in a vernier control configuration. See page 20 for details.

The SCR is switched on only as the voltage wave form crosses the zero point, which virtually eliminates radio frequency interference (RFI). All 480 and 600 volt SCR's have a 1200 peak inverse voltage (PIV) rating and transient absorbers that provide protection from high voltage spikes that can be present in 480 and 600 volt lines.

Except on single-phase heaters where the total load can be carried directly by the automatically resettable thermal limit control (see Table V, page 14), all heaters with SCR's require the limit control to be wired in series with the coil of one or more safety contactors.

The S10 Series step controller is a UL recognized low voltage 24 VAC microcomputer-based stage controller designed to provide low cost precision control for multi-stage applications. Some noted features are:

- Capable of controlling 24, 120 or 240 VAC loads
- 10 stage controller with a pulsed 12 VDC vernier stage rated at 100 mA.
- Up to 20 stages of control when using two units wired in a master & slave configuration
- 24 VDC power supply rated at 200 mA is available for an external sensor.
- Field selectable standard temperature control inputs to support input devices for 4-20 mA, 0-10 VDC, 0-20 VDC, 2200 ohm, 135 ohm and a 3-wire remote thermostat with 0-10 VDC output.
- Supports field selectable custom VDC input ranges with low and high setpoints anywhere between 0-19 VDC .
- Stage delay settings for both 'ON' and 'OFF' operation can be individually set in the field at any value between 1 second and 10 minutes.
- Functional test mode operation and LED indicators provided for use in troubleshooting.

## Step Controllers

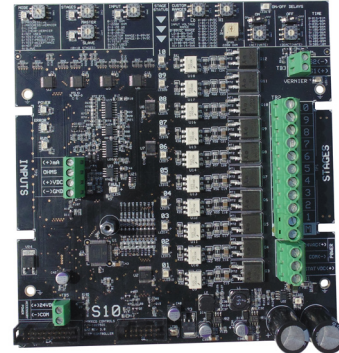

Figure 36. S10 Electronic Sequencers

Upon momentary power interruption, the controller will de-energize in order to avoid heavy line surges and to provide a soft start when power is restored.

# Construction Electrical

## Step Controllers

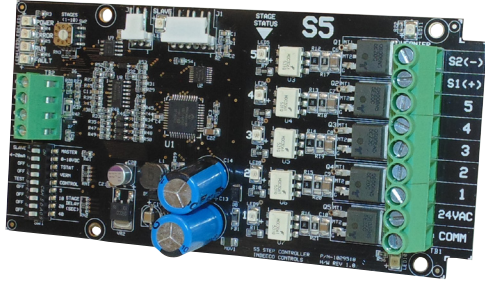

Figure 37. S5 Electronic Sequencer

Indeeco's S5 Series step controller is a low voltage Class II, 24 VAC microcomputer-based stage controller designed to provide low cost precise control for multi-stage applications.

- Capable of controlling 24 VAC loads
- 5 stage controller with a pulsed 12 VDC vernier stage rated at 100 mA.
- Up to 10 stages of control when using a slave unit
- Field selectable standard temperature control inputs to support input devices for 4-20 mA, 0-10 VDC and a 3-wire remote thermostat with 0-10 VDC output.
- Field adjustable 1-75 second 'ON' and 'OFF' stage delay.

### Vernier Proportional Control:

The S5 and S10 Series step controllers support a 12 VDC pulsed vernier stage to operate a slave SCR controller. This will result in more precise temperature control than is otherwise possible with a standard on-off step controller. The slave SCR power controller provides proportional control (0-100% load) between the switching of the step controller stages.

Recommended for large KW heaters, the economical vernier control system offers many of the advantages of a full heater SCR control. One vernier heater stage is connected to a slave SCR controller. Additional stages are sequenced on and off while the SCR vernier stage fills the gap between the step controlled stages. This provides full proportional control over the entire heater KW range. Both the SCR vernier stage and the step-controlled stages are controlled by the electronic step controller. The vernier system is normally recommended for three-phase heaters drawing more than 96 amps and single-phase heaters drawing more than 192. (see Table III, page 11)

For proportional vernier control systems used with building management systems, Indeeco recommends that the SCR stage be sized the same KW as the stepped-stages for optimum control. See Figure 39.

Multi-stage discharge temperature control of a duct heater may produce unacceptable temperature swings, resulting in poor comfort levels and an inefficient use of energy. The multi-stage controller produces a stepped output KW profile as it switches stages of heat on and off in response to varying input control signals. See Figure 38. The same heater using an SCR controller on a one second time base will produce a temperature profile that closely follows the temperature set point. This has the result of providing stable and even heat distribution for maximum comfort and efficiency. See Figure 39.

Sequence Control without Vernier:

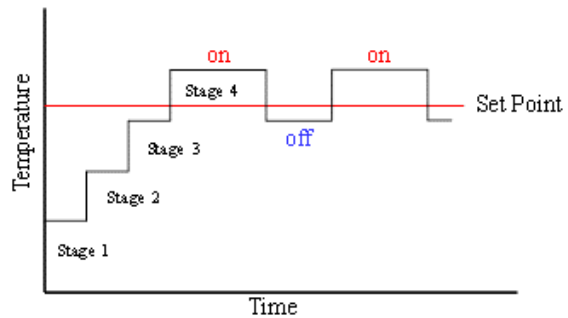

Figure 38.

Sequence Control with Vernier:

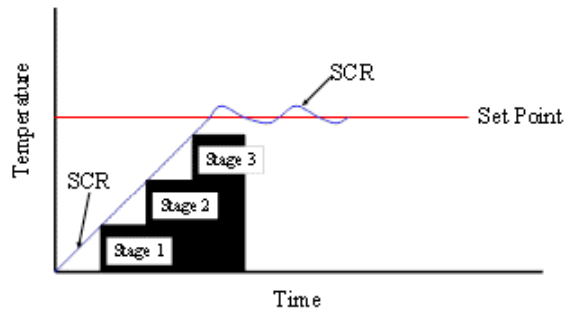

Figure 39.

## Thermostats and Sensors for Electronic Controls

An electronic proportional room thermostat (page 12, Figure 16) is standard for all Indeeco SCR and electronic step controllers. A duct type sensor is also available (page 13, Figure 21).

When a field-supplied sensor is used, the sensor can be specified with any of the inputs listed in Table VI:

**Table VI**

Available Input Signal Types for Indeeco Controllers:

Inputs <sup>1</sup>	Spans (Factory Set)		
	SCR's	S5 Step Controller	S10 Step Controller
2200 ohms	100 ohms	N/A	40-400 ohm (Adjustable)
135 ohms	100 ohms	N/A	120 ohms
4-20 mA2	12.8 mA	15 mA	15 mA
0-10 VDC	8.0 VDC	9 VDC	9 VDC

- All inputs listed in the table above are available with QUA and QUZ type heaters. These inputs plus a variety of other inputs are available with custom heaters.
- Standard input impedance is 10KΩ for VDC inputs and 250Ω for mA inputs

## Custom Control Capabilities

While standard Indeeco SCR's and step controllers satisfy the majority of HVAC applications, a much broader range of special capabilities are also available with Indeeco custom heaters. Some typical examples are:

- Fan Motor Hookup and Protection – In addition to control of the heater, it is often desirable to branch the fan motor power from the heater supply circuit. The heater is designed so that the electrician brings only one power circuit into the heater wiring enclosure which is then internally subdivided for fan power. The motor starter, overloads and overcurrent protection for the auxiliary fan motor circuit will be provided.
- Low Limit Discharge Control – A thermostat is placed in the occupied area which has primary control of the heater. A second thermostat is wired in parallel and placed in the discharge duct. This second thermostat will override the room thermostat and is set to keep the discharge air temperature above a predetermined temperature. This prevents cold air from being discharged into the occupied area.
- Temperature Averaging – Multiple sensors, with a single set point, are placed in different zones or in several locations of a large area, such as a warehouse. The controller averages the readings of all the sensors to determine the heater output. This design can be used in the hot deck of multizone units.

# Construction Mechanical

## Slip-In Heaters

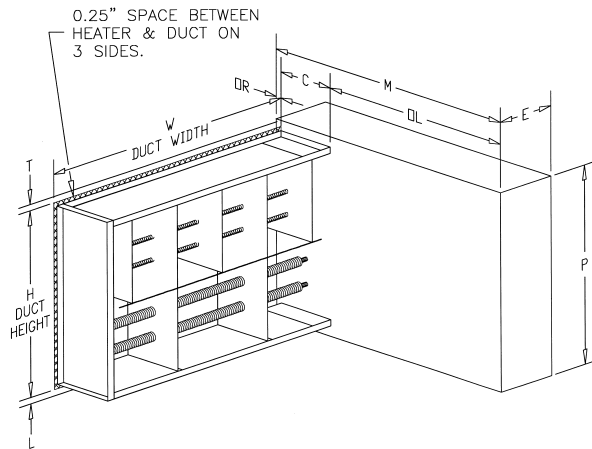

Figure 40.

Slip-in heaters are designed so that the entire frame, except the terminal box, slips into the duct with 1/4" (6.35mm) clearance all around. It is installed, as shown in Figure 8 on page 8, through a rectangular opening in the side of the duct and held in place with sheet metal screws through the back of the terminal box, which is large enough to provide a seal with the duct. Figure 40 illustrates the construction and provides reference dimensions.

Slip-in construction is used because it allows duct work to be installed before the heaters are available, simplifies on-the-job changes in heater location, and is easily retrofitted into existing duct systems. Furthermore, small slip-in heaters may be installed without any special provisions for their support.

While custom slip-in heaters can be provided to fit specific duct dimensions (W x H), selecting standard open coil type QUA heaters maximizes economy and minimizes delivery times.

Flanged construction is available with inside face dimensions exactly matching the duct dimensions. The heater frame is attached to matching turned out duct flanges as illustrated in Figure 9 on page 8. Standard flanges are a minimum of

## Flanged Heaters

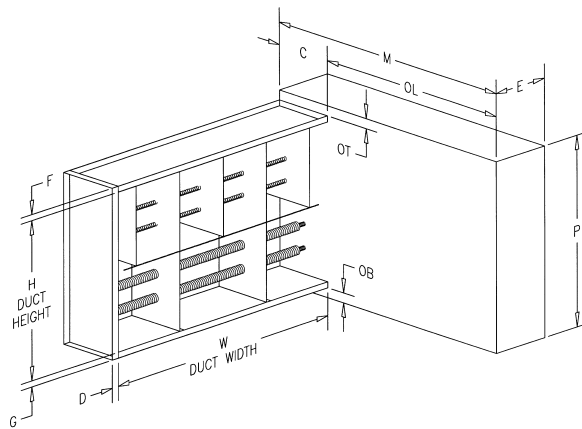

Figure 41.

3/4" deep; deeper flanges are provided on larger heaters for structural reasons. Custom flanges can be provided upon request. Figure 41 illustrates flanged heater construction and provides reference dimensions.

Standard QUA flanged heaters are available to meet many of the commonly used duct sizes. Listings of the available sizes are shown on page 25. Full range of control options and construction features are offered.

## Zero Clearance Construction

Slip-in and flanged heaters are UL Listed for zero clearance, allowing combustible material to be placed directly against surrounding duct work. Although this construction is not required by UL on heaters above 50 KW, Indeeco supplies it on all heaters regardless of KW. However, incorrect mounting will void the UL Listing, and may make the installation unsafe.

## Physical Standards

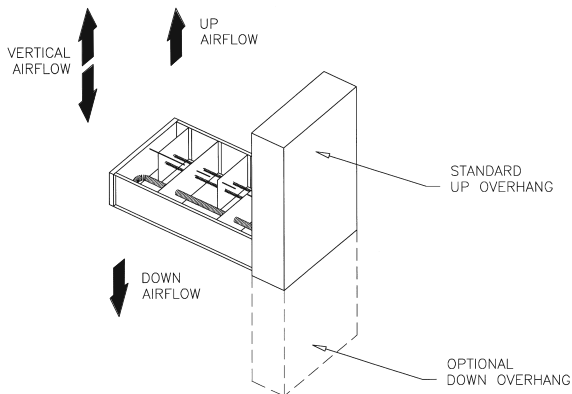

Figure 42.

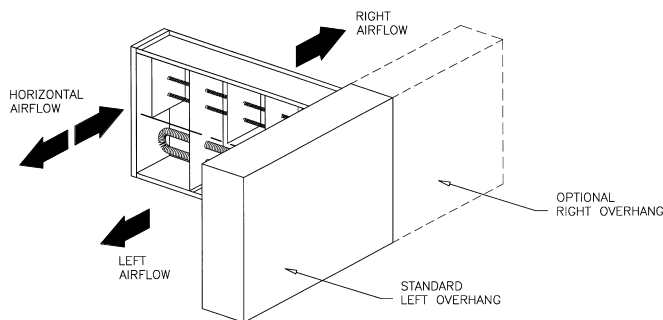

Figure 43.

Standardized dimensions and terminology avoid errors and confusion. The most common dimensions are defined in Figures 40 and 41.

Figures 42 and 43 illustrate airflow terminology. Most Indeeco open coil type heaters are suitable for horizontal or vertical airflow, but for finned tubular type heaters or heaters with pressure plates, exact airflow direction (right, left, up or down) must be specified.

In most heaters, the terminal box is significantly larger than the heater frame, in at least one direction. This is referred to as the terminal box overhang, defined in Figures 42 and 43. For horizontal airflow, left overhang is standard. For vertical airflow, up overhang is standard. Optional right and down overhangs are also available.

## Heater Frame and Terminal Box

Frames and terminal boxes are fabricated from heavy gauge corrosion resistant steel. Optional stainless steel frames are recommended for wet or corrosive applications. Standard NEMA 1 type terminal boxes have hinged covers.

Knockouts are provided for all field connections. Open coil heater element support brackets are spaced on 4.5" (114 mm) maximum centers to avoid coil sag, even under the most extreme operating conditions. Strengthening ribs on the brackets insure that coils are held in their proper location, even on large heaters.

Finned tubular heater element support brackets are spaced on 36" (914 mm) maximum centers.



# Standard Duct Heater Open Coil

## QUA Slip-In and QUZ Flanged Heaters

Figure 44.

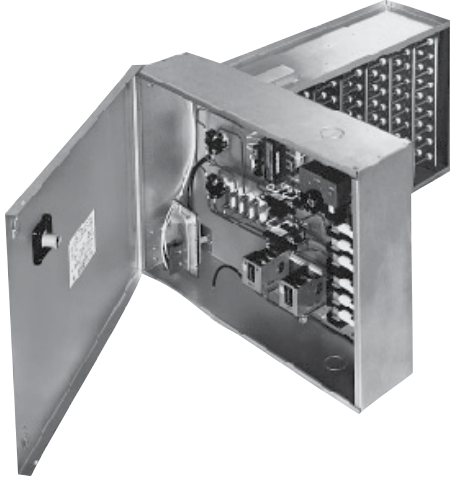

Indeeco has developed QUA (Figure 44) and QUZ (Figure 46) heater lines to satisfy most typical space heating requirements, simplifying specification, ordering and delivery.

Both standard and quick ship delivery programs are available for the full line of QUA and QUZ heaters.

### KW Ratings

QUA and QUZ heaters are available up to 456 KW. The KW ratings are limited both by frame size and electrical characteristics. Heater availability can be determined by contacting an Indeeco representative, who can provide a computerized heater selection with exact heater dimensions in minutes.

### Frame Sizes

The use of a standard open coil QUA slip-in heater will both reduce cost and permit rapid shipment. QUA frame sizes range from the smallest at 8" wide by 6" high to the largest 48" wide by 40" high or 72" wide by 30" high. The QUA offering has been opened up to allow for any duct size in between these sizes and includes fractional widths and heights dimensions (i.e. 24.625" by 17.25"). Indeeco can manufacture a custom slip-in frame size if your requirements exceed the QUA offering.

**The 80% Rule** – Indeeco recommends the heater should occupy at least 80% of the actual inside area of the duct, as shown in Figure 45. Only small amounts of air will bypass the heater around its perimeter and normal turbulence will rapidly mix this unheated air with heated air downstream.

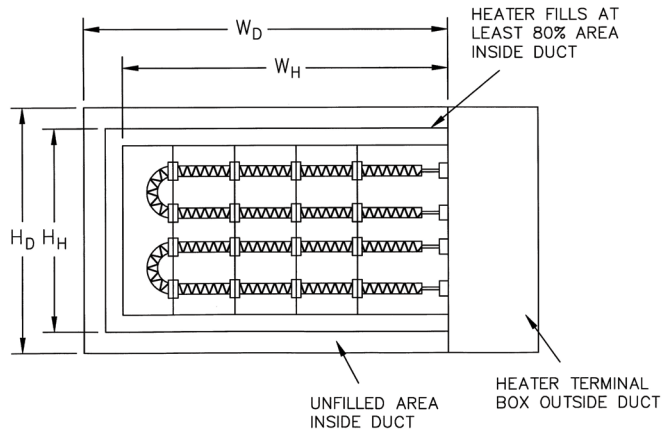

Figure 45.

All QUA heaters may be installed in ducts with up to 1" of interior lining, but the heater must be selected to fit the inside duct dimensions. For example, to fit a duct with 36" x 16" outside dimensions, but with 1" of interior insulation, specify a 35" x 14" heater.

QUZ flanged open coil heater frame sizes range from the smallest at 8" wide by 6" high to the largest at 48" wide by 38" high or 72" wide by 28" high or any duct size in between these sizes (i.e. 35.75" by 27.75").

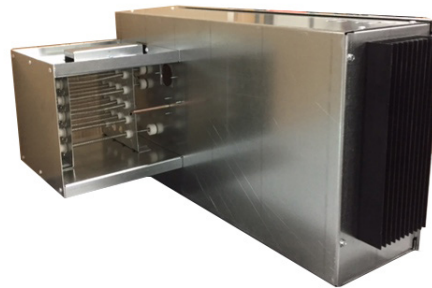

Figure 46.

# Standard Duct Heater Open Coil

Table VII

Commonly used duct widths and heights are shown in the charts below, in-between widths and heights are also available as standard QUA (slip-in) and QUZ (flanged) duct heaters.

## Sizes and Maximum KW Ratings

		Duct Height											
		6"	8"	10"	12"	14"	16"	18"	20"	24"	30"	36"	40"
Duct Width	8"	6	9	12	16	19	22	25	28	35	45	54	61
	10"	8	12	16	20	24	28	33	37	45	57	70	78
	12"	10	15	20	25	30	35	40	45	55	70	85	96
	14"	11	17	23	29	35	41	47	53	65	83	101	113
	16"	13	20	27	34	41	48	55	62	75	96	117	131
	18"	15	23	31	39	46	54	62	70	85	109	132	148
	20"	17	26	34	43	52	61	69	78	96	122	148	165
	22"	19	28	38	48	57	67	77	86	106	135	164	183
	24"	21	31	42	52	63	74	84	95	116	148	179	200
	26"	22	34	45	57	68	80	91	103	126	160	195	218
	28"	24	37	49	62	74	86	99	111	136	173	211	235
	30"	26	39	53	66	79	93	106	119	146	186	226	253
	32"	28	42	57	71	85	99	114	128	156	199	242	270
	34"	30	45	60	75	91	106	121	136	166	212	257	288
	36"	32	48	64	80	96	112	128	144	176	225	273	305
	38"	34	51	68	85	102	119	136	153	187	238	289	323
	40"	35	53	71	89	107	125	143	161	197	251	304	340
	42"	37	56	75	94	113	131	150	169	207	263	320	358
	44"	39	59	79	98	118	138	158	177	217	276	336	375
	48"	43	64	86	108	129	151	172	194	237	302	367	410
54"	48	73	97	121	146	170	194	219	268	341	—	—	
60"	54	81	108	135	162	189	216	244	298	379	—	—	
66"	59	89	119	149	179	209	239	268	328	418	—	—	
72"	65	97	130	163	195	228	261	293	359	456	—	—	

### Type QUA Slip-in Heater

Maximum KW ratings in available frame sizes shown at left.

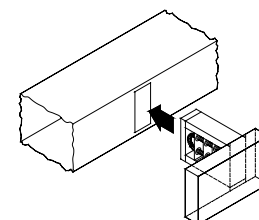

Figure 47.  
Installation of Slip-in Heater

		Duct Height											
		6"	8"	10"	12"	14"	16"	18"	22"	28"	30"	34"	38"
Duct Width	8"	11	14	18	22	25	29	33	40	51	55	62	69
	10"	13	18	22	27	32	36	41	50	64	68	78	87
	12"	16	22	27	33	38	44	49	60	77	82	93	104
	14"	19	25	32	38	45	51	57	70	90	96	109	122
	16"	22	29	36	44	51	58	66	80	102	110	125	139
	18"	24	33	41	49	57	66	74	91	115	124	140	157
	20"	27	36	45	55	64	73	82	101	128	137	156	174
	22"	30	40	50	60	70	80	91	111	141	151	171	192
	24"	33	44	55	66	77	88	99	121	154	165	187	209
	26"	35	47	59	71	83	95	107	131	167	179	203	227
	28"	38	51	64	77	90	102	115	141	180	193	218	244
	30"	41	55	68	82	96	110	124	151	193	206	234	262
	32"	44	58	73	88	102	117	132	161	205	220	250	279
	34"	46	62	78	93	109	125	140	171	218	234	265	296
	36"	49	66	82	99	115	132	148	182	231	248	281	314
	38"	52	69	87	104	122	139	157	192	244	262	296	331
	40"	55	73	91	110	128	147	165	202	257	275	312	349
	42"	57	77	96	115	135	154	173	212	270	289	328	366
	44"	60	80	101	121	141	161	182	222	283	303	343	384
	48"	66	88	110	132	154	176	198	242	308	331	375	419
54"	74	99	124	148	173	198	223	273	347	—	—	—	
60"	82	110	137	165	193	220	248	303	386	—	—	—	
66"	91	121	151	182	212	242	273	333	424	—	—	—	
72"	99	132	165	198	231	264	297	364	463	—	—	—	

### Type QUZ Flanged Heater

Maximum KW ratings in available frame sizes shown at left.

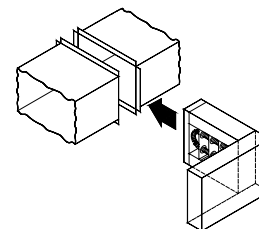

Figure 48.  
Installation of Flanged Heater

Note: Maximum KW ratings may vary based on voltage and phase combinations.

# Standard Duct Heater Open Coil

## Detail Dimensions

The wide variety of QUA and QUZ (Figures 47 and 48) heaters makes it impractical to list the exact heater dimensions for every possible heater. For dimensional details, contact your local Indeeco representative.

## Voltage and Phase

Heaters are available in the voltage and phase combinations shown below. All are for operation at 50 or 60 Hz.

When three-phase is specified, each heating stage will be furnished with a multiple of three elements to give a balanced three-phase load.

Voltage	120 208 240 277	208 240 380 400 415 480 600
Phase	1	3

## Control Circuit Options & Special Features

QUA and QUZ heaters are available with Control Options G, J and K and a full range of Special Features. These are described briefly in **Table VIII** and in more detail in the standard Control Options section of this catalog, pages 10 and 11.

## Number of Heating Stages

Single and three-phase QUA and QUZ heaters are available with multiple heating stages. To comply with our UL and NEC maximum circuit sizes, no stage is rated at more than 48 amps.

**Table VIII**

### Control Options

Control Option	Disconnect Switch	Thermal Cutouts	Airflow Switch	Contactors	Control Transformer	Fuses	PE Switches	SCR	Thermostat
G Basic	■	■	■	■	■	■ <sup>1</sup>			
J Pneumatic	■	■	■	■ <sup>2</sup>	■ <sup>3</sup>	■ <sup>1</sup>	■		
K Proportional	■	■	■	■ <sup>2</sup>	■	■ <sup>1</sup>		■	■ <sup>4</sup>

**Notes:**

1. Fuses supplied only on heaters over 48 amps.
2. Contactors supplied only when other devices cannot carry heater load.
3. Transformer only supplied on heaters rated higher than 277 volts.
4. Choice of room or duct thermostat, 135 ohms, 2200 ohms, 0-10 VDC or 4-20 mA inputs.

See pages 12 and 13 for full description of thermostats.

# Standard Duct Heater Open Coil

## Special Features

While QUA slip-in and QUZ flanged heaters may be specified with one of the standard control circuit options, individual job requirements may demand slight variations from the standards. The most common variations are covered by Indeeco's set of Special Features which may be used to modify QUA/QUZ heaters both mechanically and electrically. These are listed in **Table IX**

with a brief description, availability, and notes on any limitations of their use.

**Table X** provides a summary of thermostats offered with Indeeco QUA/QUZ heaters. See pages 12 and 13 for more detailed descriptions.

**Table IX**

Special Features	Special Feature Code	Description	Page Ref.	Availability & Limitations
<b>Mechanical</b>				
Horizontal Airflow	U8	Allows heater to be used in applications where airflow is either right (U4) or left (U6)	27	Available on all heaters.
Vertical Airflow	U9	Allows heater to be used in applications where airflow is either vertical up (U3) or vertical down (U5.)	27	Available on all heaters.
Pressure Plate	V1	40% open perforated plate installed onto the inlet side of the heater frame to help even out irregular airflow patterns.	39	Available on all heaters. Exact airflow direction must be specified U3, U4, U5 or U6.
Protective Screen	V/V2	Wire mesh screen for attachment to the heater frame. Can be furnished for one or both sides.	40	Available on all heaters. Screens are shipped loose for field installation.
Stainless Steel Frame and Terminal Box	H2	Heater frame and terminal box constructed of 304 stainless steel.		Available on all heaters.
Aluminized Steel Frame and Terminal Box	H1	Heater frame and terminal box constructed of aluminized steel.		Available on all heaters.
Insulated Duct Construction for Slip-in Heaters	GG2	Used in ducts lined with more than 1" thick interior insulation. Inside duct dimensions and insulation thickness must be specified. Maximum 6" thick lining.	40	Available on all heaters.
Unheated Sections	G2	Extended terminal pins to provide an unheated section adjacent to the heater terminal box. Maximum extended terminal pin length of 6".	40	Available on all heaters.
Substitute Negative Pressure Switch	Q5/Q6	Allows heater to be used on inlet side of fan.	19	Available on all heaters.
Right/Down Terminal Box Overhang	L4/L5	Heater will be supplied with terminal box overhang on right (if horizontal airflow installation) or downward (if vertical airflow installation).	27	Available on all heaters.

# Standard Duct Heater Open Coil

Table IX (continued)

Special Features	Special Feature Code	Description	Page Ref.	Availability & Limitations
<b>Mechanical (cont.)</b>				
Insulated Terminal Box	B2	Prevents condensation inside terminal box when heater is installed in air conditioning duct running through un-airconditioned area.	39	Available on all heaters.
Dust-Tight Terminal Box	B7	Allows installation in dusty areas and satisfies local codes requiring dust-tight box, if installed in area used as return air plenum.	38	Available on all heaters.
Remote Panelboard	B5	All controls except thermal cutouts, airflow switch and pilot switch will be supplied in a separate NEMA 1 panelboard.	41	Available on all heaters except when transformer and contactors are deleted.
<b>Electrical</b>				
Add "Stage On" Pilot Light(s)	P1	To indicate when each heating stage is producing heat.	21	Available on all heaters except Option K SCR stages.
Add "Low Airflow" and "Heater On" Pilot Lights	P2, P3	Separate pilot lights to indicate that power has been supplied to the heater, that it is ready for operation, and whether airflow has been interrupted.	21	Available on all heaters. When fan relay has been substituted for airflow switch, only "Heater On" will be supplied.
Fan Relay	N(000)	When static pressure in the duct is too low (below .07" WC) to operate the airflow switch or when airflow switch is not desired. (000) denotes holding coil 24, 120, 208, 240, or 277 volts.	19	Available on Option G & K heaters except Option G heaters where deletion of contactors and transformers is specified.
Add Indeeco Electronic Step Controller	S	Allows better temperature control of high capacity heater by using multiple stages controlled by electronic thermostat and step controller.	23-24	Only available on Option G heaters with 2 or more heating stages.
Low Watt Density Coils	D3, D4	To meet specifications which call for low watt density coils.		Available on all heaters.
Add Built-in PE Transducer	E32, S19	To allow for pneumatic control.	16	Available on Option K heaters or Option G heaters with step controller and 6 or more stages.
Transformer Primary Fusing	T1	Standard for all heaters with 120 VAC and Class I control circuits. Available with all heaters with 24 VAC and Class II control circuits.		Available with all heaters with built-in transformer.

# Standard Duct Heater Open Coil

Table IX (continued)

Special Features	Special Feature Code	Description	Page Ref.	Availability & Limitations																				
<b>Electrical (cont.)</b>																								
Delete Transformer		Allows control circuit to be obtained from source outside the heater or, when line voltage is equal to control voltage, directly from power lines within the heater.	20	Only available on Option G heaters. Must be specified if control voltage is not 120 or 24 volts. Customer must specify control volts.																				
Delete Transformer & Contactors		Allows for control of heater directly using load carrying thermostats.	20	Available only on single stage, single-phase, Option G heaters with KW not exceeding the following. <table border="1"> <tr> <td>Voltage</td> <td>120</td> <td>277</td> </tr> <tr> <td>Max KW</td> <td>1.8</td> <td>4.1</td> </tr> </table>	Voltage	120	277	Max KW	1.8	4.1														
Voltage	120	277																						
Max KW	1.8	4.1																						
Transformer Secondary Fusing	T3	External fused and grounded transformer secondary for Class II 24 volt control circuits.		Available on all heaters.																				
Additional User Control Circuit Voltage		Heater control circuit transformer sized for additional user VA. A control terminal block is furnished for field connection.		Available on all heaters. Consult factory for 1 week or 72 hour heater availability.																				
Delete Disconnect		Allows for use of field installed disconnecting means. (Must be within sight of the heater.)	20	Available on all heaters.																				
Fused Disconnect Switch	Q1	Door interlocking disconnect with line fusing for heaters loads up to 48 amps or less.	20	Available on all heaters.																				
Linear Limit Automatic Reset Thermal Cutout	Z/Z1	Automatic reset linear limit thermal cutout wired in series with the disc type automatic reset to provide redundant primary over temperature protection.	18	Available on all heaters. Exact airflow direction must be specified U3, U4, U5 or U6.																				
Add Fuses for Heaters Rated 48 Amps or Less	F1	Allows for addition of one set of fuses to low amperage heaters that do not need internal fusing to meet UL and NEC requirements	20	Available on all heaters whose KW is lower than or equal to the following. (Other heaters include fusing as standard): <table border="1"> <tr> <td rowspan="2">Line Volts</td> <td colspan="2">KW (at 48 amps)</td> </tr> <tr> <td>1 Phase</td> <td>3 Phase</td> </tr> <tr> <td>120</td> <td>5.7</td> <td>-</td> </tr> <tr> <td>208</td> <td>9.9</td> <td>17.2</td> </tr> <tr> <td>240</td> <td>11.5</td> <td>19.9</td> </tr> <tr> <td>277</td> <td>13.2</td> <td>-</td> </tr> <tr> <td>480</td> <td>23.0</td> <td>39.9</td> </tr> </table>	Line Volts	KW (at 48 amps)		1 Phase	3 Phase	120	5.7	-	208	9.9	17.2	240	11.5	19.9	277	13.2	-	480	23.0	39.9
Line Volts	KW (at 48 amps)																							
	1 Phase	3 Phase																						
120	5.7	-																						
208	9.9	17.2																						
240	11.5	19.9																						
277	13.2	-																						
480	23.0	39.9																						
Remote enable terminals	R1	Enables heater operation with remote dry contacts.		Available on all heaters.																				

# Standard Duct Heater Open Coil

**Table X**

**Summary of Thermostats Available with Option G or K Heaters (No Thermostats are supplied on Option J Heaters)**

Type of Thermostat		Used with Control Option	Catalog Number	Comments	
ROOM	Pilot Duty	1 Stage	G	1006998 (Fig.11)	Rated for 30 volts max. Offered with Duct Heater Selection
		1 Stage	G	1023721 (Fig. 12)	Digital Display, Rated for 30 volts max. Special Ordered
		2 Stage	G	1007030 (Fig. 13)	Digital Display, Rated for 30 volts max.
		2 or 3 Stage	G	1023723 (Fig. 14)	Programmable with Digital Display, Rated for 30 volts max.
	† Proportional Electronic		G or K	SCR Controlled or Vernier Controlled. 1016941 (Fig. 16)	With Option G, can be used only when step controller is also specified
DUCT	Pilot Duty	1 Stage	G	1023953 (Fig. 18)	Rated for 277 volts max.
		2 Stage	G	1007044 (Fig. 19)	Rated for 240 volts. max.
	† Proportional Electronic		G or K	SCR Controlled or Vernier Controlled. 1016941 and 1016942 (Fig. 16)	With Option G, can be used only when step controller is also specified.
† No Thermostat (Special inputs for controller or SCR when customer supplied thermostat is used)		G or K	— — —	2200 ohm Input 135 ohm Input 4-20 mA Input 0-10 VDC Input	

†A thermostat or input must be specified with all Option K heaters and all Option G heaters with step controllers. Step controllers with 4-20 mA or 0-10 VDC will be furnished with proportional control.

# Standard Duct Heater Open Coil

## QUA/QUZ – Sample Specification

A job specification can be prepared by using the following information. Simply darken the applicable circles. Material which is part of the basic specification has already been darkened. Additional copies of this specification guide are available from your local Indeeco representative.

- 1. Duct heaters shall be Indeeco
  - Type QUA Standard Slip-in Heaters
  - Type QUZ Standard Flanged Heaters
- 2. Approvals – Heaters and panelboards (if required) shall meet the requirements of the National Electrical Code and shall be listed by Underwriters Laboratories for zero spacing between the duct and combustible surfaces and for use with heat pumps and air conditioning equipment.
- 3. Heating elements shall be open coil, 80% nickel, 20% chromium, Grade A resistance wire. Type C alloys containing iron or other alloys are not acceptable. Coils shall be machine crimped into stainless steel terminals extending at least 1” into the airstream and all terminal hardware shall be stainless steel. Coils shall be supported by ceramic bushings staked into supporting brackets.
- 4. Heater frames and terminal boxes shall be corrosion resistant steel. Unless otherwise indicated, the terminal box shall be NEMA 1 type construction and shall be provided with a hinged, latching cover and multiple concentric knockouts for field wiring.
- 5. All heaters shall be furnished with a disc type, automatic reset thermal cutout for primary over-temperature protection. All heaters shall also be furnished with disc type, load carrying manual reset thermal cutouts, factory wired in series with heater stages for secondary protection. Heat limiters or other fusible overtemperature devices are not acceptable.
- 6. Heaters shall be rated for the voltage, phase, and number of heating stages indicated in the schedule. All three-phase heaters shall have equal, balanced, three-phase stages. All internal wiring shall be stranded copper with 105°C insulation and shall be terminated in crimped connectors or box lugs.
- 7. Terminal blocks shall be provided for all field wiring and shall be sized for installation of 75°C copper wire rated in accordance with NEC requirements.
- 8. Heaters shall be furnished, either with the Control Option specified in the schedule and described below, or with the specific components listed in the schedule.
  - Option G – Thermal cutouts, airflow switch, contactors, fuses (if over 48 amps), control circuit transformer (where required) and built-in, snap-acting, door interlocked disconnect switch.
    - Option J – Thermal cutouts, airflow switch, PE switches, contactors (where required), fuses (if over 48 amps), control circuit transformer (where required), and built-in snap-acting door interlocked disconnect switch.
    - Option K – Thermal cutouts, airflow switch, contactors (where required), SCR (with step controller if heater draws over 96 amps three-phase or 192 amps single-phase), fuses (if over 48 amps), control circuit transformer, and built-in snap-acting door interlocked disconnect switch.
  - 9. When specified in the schedule, or below, heaters will be supplied with the following Special Features:
    - Airflow switch for negative pressure operation
    - Insulated terminal box
    - Dust-tight terminal box
    - Stainless steel frame and terminal box
    - Aluminized steel frame and terminal box
    - Insulated duct construction for slip-in heaters (>1” ≤6” thick lining)
    - Unheated section (≤6” terminal pin)
    - Pressure plate
    - Protective screen(s); ◦ one side ◦ both sides
    - Controls mounted in NEMA 1 remote panelboard
    - Deletion of transformer
    - Deletion of transformer and contactor
    - Transformer primary fusing (standard for Class I)
    - Transformer secondary fusing (Class II)
    - Additional user control circuit voltages (specify user VA)
    - Deletion of disconnect switch
    - Fused disconnect switch (≤ 48 amps)
    - Fusing for heaters rated 48 amps or less
    - “Low Airflow” pilot light
    - “Heater On” pilot light
    - Each “Stage On” pilot light(s)
    - Fan relay (instead of airflow switch)
    - Fan relay (in additional to airflow switch)
    - Remote enable heater operation
    - Step controller
    - Linear limit automatic reset thermal cutout
    - 25 watts per square inch resistance coils
    - 35 watts per square inch resistance coils
    - Built-in PE transducer
  - 10. When specified in the schedule, or below, heaters shall be supplied with the following thermostats:
    - Pilot duty single stage room thermostat
    - Pilot duty digital display single stage room thermostat
    - Pilot duty two stage digital display room thermostat
    - Pilot duty two or three stage programmable with digital display room thermostat
    - Proportional electronic room thermostat
    - Pilot duty single stage duct thermostat
    - Pilot duty two stage duct thermostat
    - Proportional electronic duct thermostat with set point adjuster
    - Special inputs (135 ohms, 2200 ohms, 4-20 mA, 0-10 VDC)



# Custom Duct Heaters

## Special Applications

**Air Conditioning & Air Handling Units** – For more than 65 years, Indeeco has been supplying heaters for use in air handling and air conditioning equipment (Figure 49). A wide range of UL recognized to standard 1995 heaters are available using special construction and design techniques to insure proper operation as well as ease of installation, either in the OEM's plant or in the field. These heaters are typically used in central station, multi-zone or dual duct air handlers.

Indeeco has higher SCCR (short circuit current ratings) available for duct heaters up to 100kA. An optional fused disconnect switch with 100KAIC rating is also an option for our heaters. Please contact your factory representative for more information.

Figure 49.

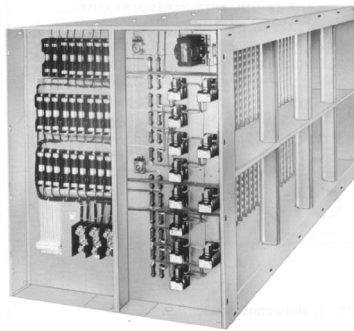

**Central Station Construction** – The heater is designed for installation as an integral component of the air handler adjacent to fans, cooling sections, filter boxes, etc. (Figure 49). Unheated sections can be provided where there is little or no airflow, such as the area blocked by an adjacent cooling coil header. Pressure plates can be used to insure uniform airflow, the use of unheated areas or derated elements can be provided to space the heating coils away from temperature sensitive components or to help assure uniform airflow.

Figure 50.

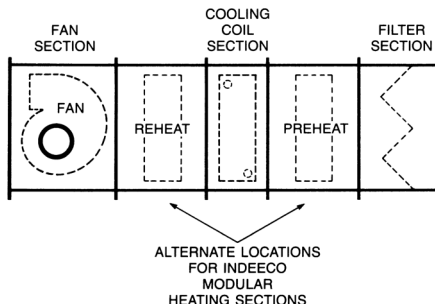

**Multi-Zone or Dual Duct Heaters** – These heaters are designed for installation inside multi-zone or dual duct air conditioning equipment, where the airflow is highly variable and unevenly distributed (Figure 51). These heaters use coils derated to approximately 25 watts per square inch (3.8 watts per square cm) of wire surface area (approximately one half normal watt density). Low density coils run cooler, and thus, provide longer life under these stringent operating conditions.

These heaters are supplied with fully proportional SCR control or with many heating stages to insure that no more heat is being supplied than is absolutely necessary. Each heater stage is spread over the entire face area to take advantage of all available airflow.

A perforated pressure plate is factory-installed on the air inlet side of the heater to make the airflow as uniform as possible. Linear limit thermal cutouts protect against serious overheating anywhere along the length of the heater.

When the heater must be installed entirely within the unit, only thermal cutouts are built into the heater, a remote panel is required for controls. When the terminal box can be external, heaters are available with a wide range of built-in controls.

Figure 51

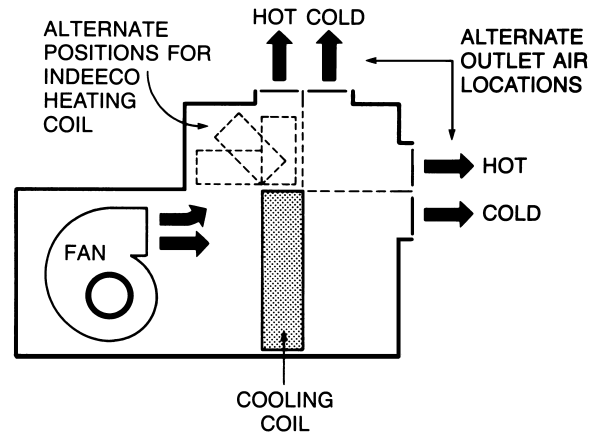

# Custom Duct Heaters

**Round Duct Construction** – Indeeco manufactures UL listed open coil duct heaters specifically designed for installation to commercially rated round ducts. Heaters are available for installation to spiral single and double wall or snap-lock round sheet metal ducts with inside diameters of 6, 8, 10, 12, 14, 16, 18, 20, 22, 24, 26 and 28 inches. Two square to round male galvanized steel transitions, Figure 53, are supplied for field installation to the inlet and outlet of the duct heater. The transitions are attached directly to the flanges of the heater and to the round duct using sheet metal screws (see Figure 52). The Indeeco transitions have been approved by UL to provide uniform airflow across the open coil elements to avoid hot spots, which could affect the performance of the heater.

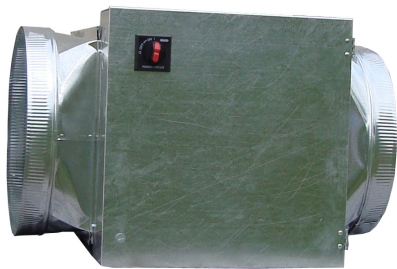

Figure 52. Open Coil heater with round duct transitions.

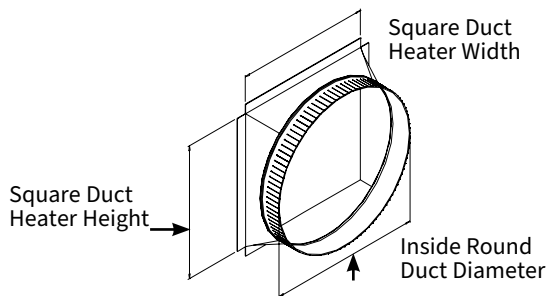

Figure 53. Square to round sheet metal transitions.

**Marine Duty** – Only Indeeco offers a UL Listed duct heater which is also ABS Design Assessed and meets U.S. Coast Guard Requirements for shipboard use (Figure 54).



Figure 54.

**Variable Air Volume (VAV) Units** – To serve the fast moving and very competitive VAV market, Indeeco has developed a fully computerized design and construction system, which enables us to ship substantial volumes of heaters in a wide variety of sizes, ratings, and control options quickly. This system was patterned after our methods of designing and producing standard duct heaters, modified to solve the problems unique to the VAV industry. Slip-and-drive sheet metal connections, control packages tailored to VAV systems, and special techniques for fan interlocks are some of the features designed for this market (Figure 55).

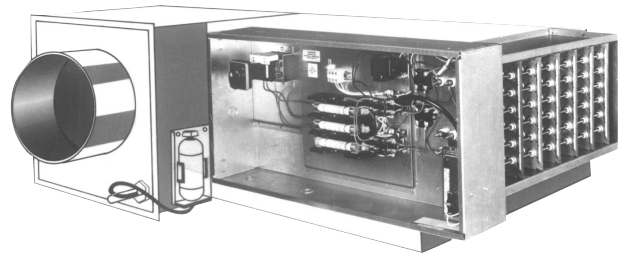

Figure 55.

**Railway and Subway Applications** – Tough rail car industry standards have been developed to overcome the severe vibration, shock, high operating voltages, and voltage swings routinely encountered. For more than 45 years, Indeeco has built heaters to meet these standards, using heavy gauge corrosion resistant steel frames and oversized coil and terminal support bushings (Figure 56).

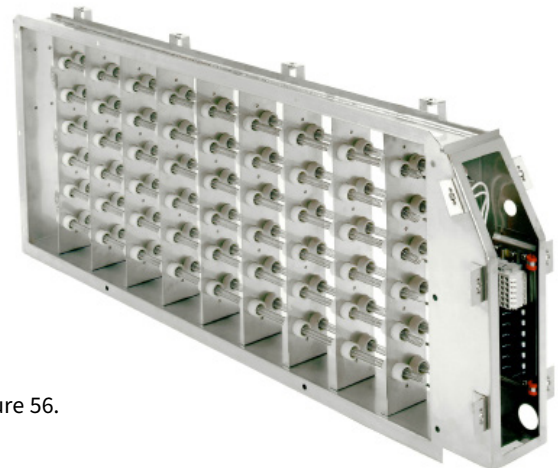

Figure 56.

# Custom Duct Heaters

## Duct Heaters for Wet, Dusty and Corrosive Areas

Indeeco offers a wide selection of custom built electric duct heater designs for outdoor, wet, dusty, and corrosive areas. Typical applications include use with roof top air handling equipment, in washdown areas such as food processing plants, wet and humid spaces near indoor swimming pools, and marine or casino boat applications including shipboard use.

### Features:

- Disconnect switch with door interlock
- Manual reset thermal cutout
- Automatic reset thermal cutout
- Stainless steel frame
- Large diameter stainless steel finned tubular heating elements
- Heavy duty control transformer
- Fusing per NEC
- Airflow switch
- Stainless steel terminal hardware

### Outdoor UL Listed 3R



Figure 57.

Outdoor type 3R heaters (Figure 57) are intended for outdoor use to provide a degree of protection against falling rain, sleet, and external ice formation. UL Listed 3R heaters can be used in most HVAC outdoor applications and indoors for protection against dripping water. Water-tight hubs for incoming power and control connections are furnished.

### Dust-tight Construction

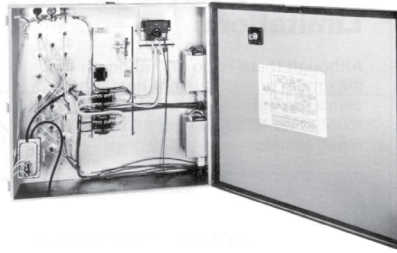

Figure 58.

A dust-tight terminal box (Figure 58) is available to meet local codes that require dust-tight construction for a heater installed above a false ceiling when the entire area is used as a return air plenum. It is also suitable for commercial or light industrial applications to avoid dust accumulation inside the terminal box while a building is under construction.

These boxes are spot welded corrosion resistant steel, with all openings sealed. The hinged cover is gasketed and hold-down clamps are provided. (Note that this construction does not meet the more rigid requirements of NEMA 12 described below).

### NEMA 12 Type Terminal Box

For heavy duty industrial applications involving both dust and oil, NEMA 12 type construction is available on custom heaters (Figure 59). The all welded, stainless steel terminal box has a hinged, gasketed cover with hold-down clamps. Scru-tite hubs for line and power connections are included.

Figure 59.

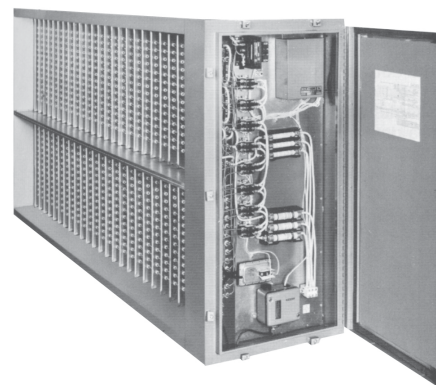

### NEMA 4 Type Terminal Box

For weatherproof locations and washdown areas, such as food processing plants, a NEMA 4 type construction is available. This all welded stainless steel enclosure is furnished with a hinged, gasketed cover and is provided with water-tight hubs for incoming power and control connections.

# Custom Duct Heaters

## Bottom Mounted Terminal Box

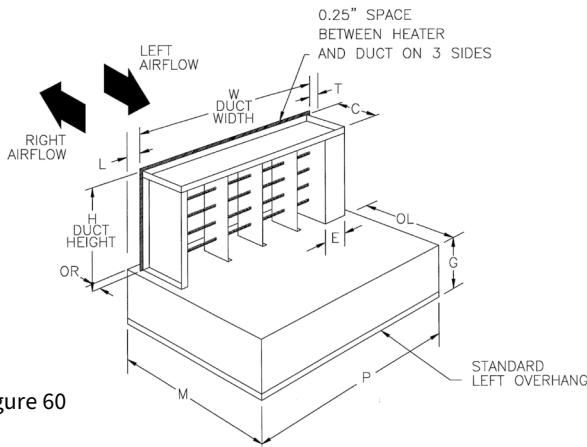

Figure 60

The NEC requires a work space at least 30" (76 cm) wide by 42" (107 cm) deep in front of a heater terminal box for service access. More space is required for large heaters. When this space is not available at the side of a duct, the heater can be installed through the bottom, using a special bottom mounted terminal box construction, which maintains the required horizontal orientation of open coil resistance elements.

Custom heaters of either flanged or slip-in design are available with this feature. However, slip-in is normally preferred for ease of installation (Figure 60). UL Listed heaters are limited to the sizes indicated in **Table XIII**.

**Table XIII**

**Duct Size Limitations of Bottom Terminal Box Heaters**

Heater Type	Minimum W in (mm)	Minimum H in (mm)	Maximum H in (mm)
Open Coil Flanged	5 (127)	3 (76.2)	40 (1016)
Open Coil Flange	8 (208)	4.25 (108)	40 (1016)
Finned Tubular Flanged	4.5 (114)	4 (102)	72 (1829)
Finned Tubular Slip-in	11 (279)	5.25 (133)	72 (1829)

## Insulated Terminal Box

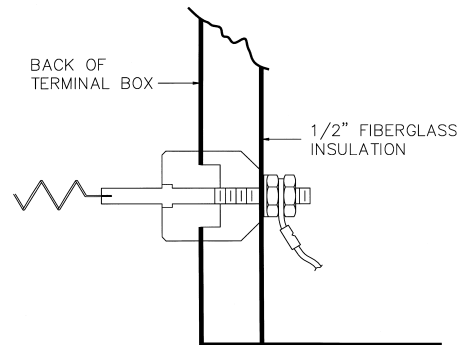

Figure 61.

When the heater is installed in an air conditioning duct which runs through an un-airconditioned space, condensation may form inside the terminal box. To eliminate this condensation or for energy conservation, the back of the terminal box can be factory insulated (Figure 61). This construction is available with all heaters.

## Pressure Plates

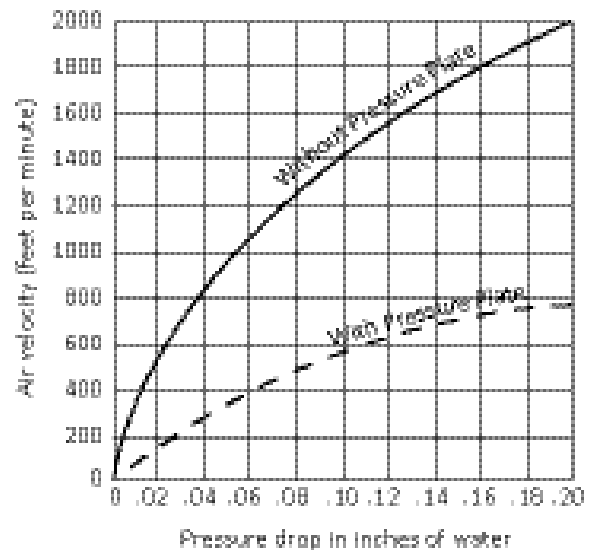

Figure 62.

A 40% open pressure plate on the inlet side of open coil type heaters evens out the airflow pattern in installations where it is not uniform. A pressure plate significantly increases the pressure drop across the heater (Figure 62). This increase must be considered in sizing the fan motor. To assure correct plate location, specify the exact airflow direction as defined in Figures 42 and 43, page 23.

# Custom Duct Heaters

## Protective Screens

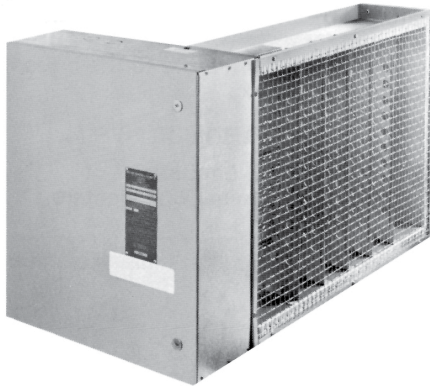

Figure 63.

Protective screens protect personnel from accidental contact with electrically hot open coil elements and prevent large airborne contamination from reaching the elements (Figure 63). The 3/8" (9.5mm) wire mesh screen may be mounted on both sides of the heater. Finned tubular duct heater construction may be more appropriate for these applications.

## Unheated Sections

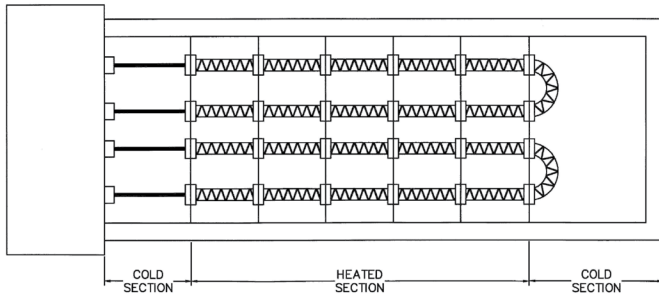

Figure 64.

Indeco custom heaters can be supplied with unheated sections, either open or blocked off (Figure 64). Such constructions are particularly helpful when the heater frame must extend through an area with little or no airflow to maintain accessibility to the terminal box. For example, a heater next to a cooling coil should have extended terminal pins so no heat is generated adjacent to the cooling coil header. Most constructions are available with a UL label.

## Construction For Lined Ducts

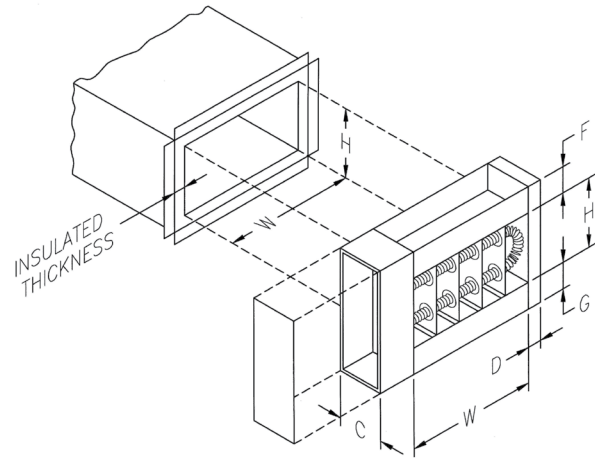

Figure 65. Installation of flange type heater in lined duct

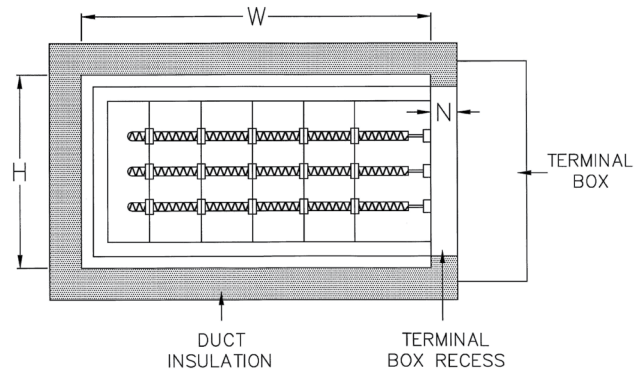

Figure 66. Installation of slip-in heater where insulation is more than 1" (25.4 mm) thick

All Indeco slip-in heaters are suitable for use in ducts lined with up to 1" (25.4 mm) of interior insulation. Extended terminals and the design of the thermal cutout system make standard slip-in heaters suitable for such installations without any deterioration in performance or life. Be sure that the duct dimensions specified are those inside the duct lining.

For slip-in heater applications where the insulation is more than 1" (25.4 mm) thick or where flanged heaters are required, the special constructions illustrated in Figures 65 and 66. Dimensions inside the insulation must be specified as well as the insulation thickness.

# Custom Duct Heaters

## Slip-and-Drive Construction

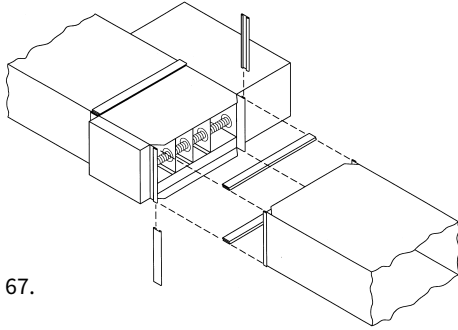

Figure 67.

This option for custom flanged heaters, allowing installation with conventional HVAC slip-and-drive connections, offers the rugged and secure mounting of a flanged heater, yet requires less installation labor than a slip-in heater. It is particularly useful when other equipment in the duct system uses slip-and-drive connections, as the contractor can standardize throughout (Figure 67).

By using Indeeco's slip-and-drive construction in variable air volume (VAV) units, the manufacturer can offer the same standard VAV box for electric heat, hot water heat, or no heat.

## Remote Panelboard

When specifying remote panelboards (Figure 68), we recommend the following changes in control and safety components to insure the safety of the installation and to minimize the field labor costs.

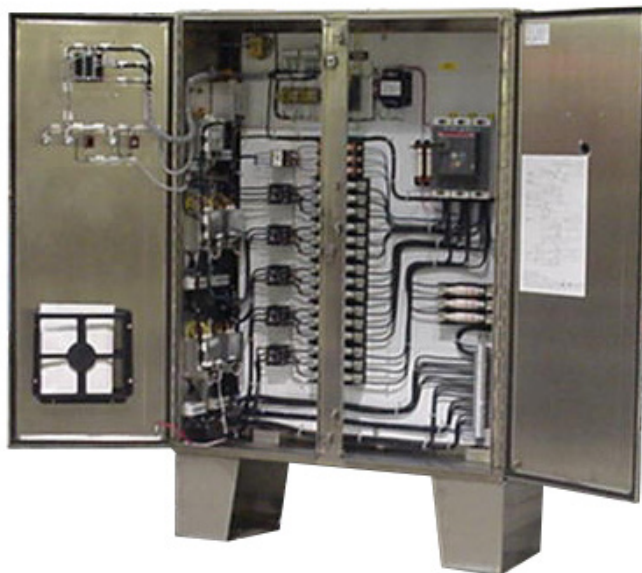

Figure 68.

- Contactors – Use disconnecting controlling contactors which break all ungrounded lines. Thus, when heat is not being called for, all terminals in the heater will be dead.
- Pilot Switch – Add a dead front pilot switch to the heater terminal box to make it safe for servicing by simply tripping the pilot switch. This shuts off power to the heater circuits through the disconnecting contactors in the panel.
- Fuses – Built-in fusing for each panelboard will be in accordance with UL and NEC requirements.

Except for SCR's, which are mounted through the panelboard side wall, control components are mounted on a sub-panel. Labeled terminal blocks are provided for all field wiring, both in the panel and in the heater. Knockouts and wiring gutter spaces are supplied in all panelboards.

NEMA 1 panels are made from heavy gauge steel, welded and painted (as required), and are provided with a lock and key. Wall mounting, flush mounting, or floor mounting on legs are available.

NEMA 3R type panelboards for outdoor use are UL Listed. These are intended for outdoor use to provide protection against falling rain, sleet, and external ice formation.

NEMA 4 and NEMA 12 UL Listed panelboards for outdoor, dusty, and oil atmospheres are also available. Explosion-proof panels furnished with cast aluminum enclosures are available.

All standard type QUA and QUZ heaters are available with remote panels. Panels for these standard heaters are available in NEMA 1 wall or floor mounting. Fusing, disconnecting contactors, and a heater-mounted pilot switch, all as described above, are supplied.

# Custom Duct Heaters

## Minimum & Maximum Duct Dimensions

Although there is no limitation on the maximum size of custom heater assemblies, individual UL Listed heaters must meet the following minimum and maximum requirements (see tables below).

UL Listed custom heaters are also available in virtually any KW rating. However, heaters are restricted to maximum KW ratings based on the square feet of heated area.

Indeeco has built individual duct heaters for space heating applications ranging from 0.1 KW to over 900 KW, multi-section units with up to 2000 KW in one assembly, and face areas as large as 40' wide x 14' high. Exact dimensional and KW limits can be determined by contacting your local Indeeco representative.

**Table XIV**  
**Open Coil Custom Heaters**

	Slip-in Type in (mm)	Flanged Type in (mm)
Minimum Duct Width (W)	5.25 (133)	5 (127)
Minimum Duct Height (H)	4.25 (108)	3 (76)
Maximum Duct Width (W)	240 (6100)	240 (6100)
Maximum Duct Height (H)	120 (3050)	120 (3050)

**Table XV**  
**Finned Tubular Custom Heaters**

	Slip-in Type in (mm)	Flanged Type in (mm)
Minimum Duct Width (W)	4.75 (121)	4.5 (114)
Minimum Duct Height (H)	5.25 (133)	4 (102)
Maximum Duct Width (W)	175 (4450)	175 (4450)
Maximum Duct Height (H)	120 (3050)	120 (3050)

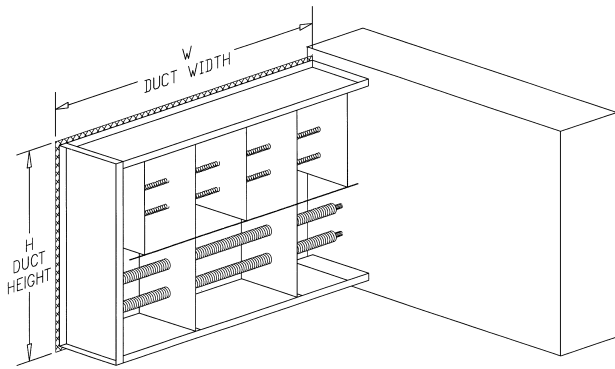

Figure 69. Slip-in Duct Heater

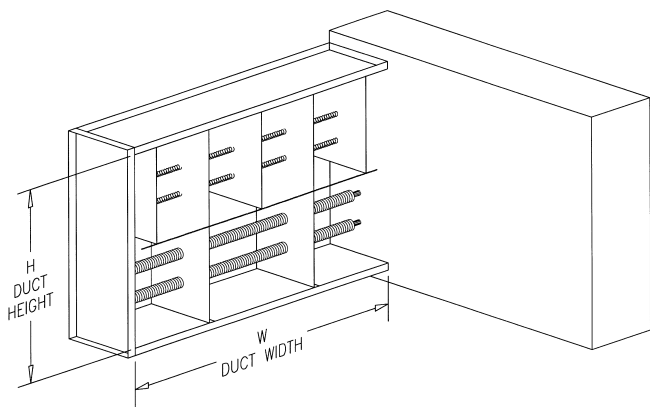

Figure 70. Flanged Duct Heater

## Open Coil Custom Heater – Sample Specification

A job specification can be prepared by using the following information. Simply darken the applicable circles. Material which is part of the basic specification has already been darkened. Additional copies of this specification guide are available from your local Indeeco representative.

- 1. Duct heaters shall be Indeeco:
  - Type XUB Custom Slip-in Heater
  - Type ZUB Custom Flanged Heater
- 2. Approvals – Heaters and panelboards (if required) shall meet the requirements of the National Electrical Code and shall be listed by Underwriters Laboratories for zero space between the duct and combustible surfaces and for use with heat pumps and air conditioning equipment.
- 3. Heating elements shall be open coil, 80% nickel, 20% chromium, Grade A resistance wire. Type C alloys containing iron or other alloys are not acceptable. Coils shall be machine crimped into stainless steel terminals extending at least 1” into the airstream and all terminal hardware shall be stainless steel. Coils shall be supported by ceramic bushings staked into supporting brackets.
- 4. Heater frames and terminal boxes shall be corrosion resistant steel. Unless otherwise indicated, the terminal box shall be NEMA 1 type construction and shall be provided with a hinged, latching cover and multiple concentric knockouts for field wiring.
- 5. All heaters shall be furnished with a disc type, automatic reset thermal cutout for primary overtemperature protection. All heaters shall also be furnished with disc type, load-carrying manual reset thermal cutouts, factory wired in series with heater stages for secondary protection. Heat limiters or other fusible overtemperature devices are not acceptable.
- 6. Heaters shall be rated for the voltage, phase, and number of heating stages indicated in the schedule. All three-phase heaters shall have equal, balanced, three-phase stages. All internal wiring shall be stranded copper with 105°C insulation and shall be terminated in crimped connectors or box lugs.
- 7. Terminal blocks shall be provided for all field wiring and shall be sized for installation of 75°C copper wire, rated in accordance with NEC requirements.
- 8. Heaters shall be furnished, either with the Control Option specified in the schedule and described below, or with the specific components listed in the schedule.
  - Option G – Thermal cutouts, airflow switch, contactors, fuses (if over 48 amps), control circuit transformer (where required) and built-in snap-acting door interlocked disconnect switch.
  - Option J – Thermal cutouts, airflow switch, PE switches, contactors (where required), fuses (if over 48 amps), control circuit transformer (where required) and built-in snap-acting door interlocked disconnect switch.
  - Option K – Thermal cutouts, airflow switch, contactors (where required), SCR (with step controller and contactors, if heater draws over 96 amps, three-phase or 192 amps single-phase), fuses (if over 48 amps), control circuit transformer (where required), and built-in snap-acting door interlocked disconnect switch.
- 9. When specified in the schedule, or below, heaters will be supplied with the following Special Features:
  - Airflow switch for negative pressure operation
  - Insulated terminal box
  - Dust-tight terminal box
  - Special terminal box construction
    - NEMA 1 ◦ UL3R ◦ NEMA 12 ◦ NEMA 4 ◦ NEMA 4X
  - Stainless steel frame and terminal box
  - Aluminized steel frame and terminal box
  - Insulated duct construction for slip-in heaters
  - Unheated section
  - Pressure plate
  - Protective screen(s); ◦ one side ◦ both sides
  - Controls mounted in remote panelboard
    - NEMA 1 ◦ UL3R ◦ NEMA 12 ◦ NEMA 4 ◦ NEMA 4X
  - Deletion of transformer
  - Deletion of transformer and contactor
  - Transformer primary fusing (standard for Class I)
  - Transformer secondary fusing (Class II)
  - Additional user control circuit voltage (specify user VA)
  - Deletion of disconnect switch
  - Fused disconnect switch (≤ 48 amps)
  - Fusing for heaters rated 48 amps or less
  - “Low Airflow” pilot light
  - “Heater On” pilot light
  - “Overtemperature” pilot light
  - Each “Stage On” pilot light(s)
  - Fan relay (instead of airflow switch)
  - Fan relay (in addition to airflow switch)
  - Remote enable heater operation
  - Step controller
  - Linear limit automatic reset thermal cutout
  - 25 watts per square inch resistance coils
  - 35 watts per square inch resistance coils
  - Built-in PE transducer
  - Round Duct Construction
- 10. When specified in the schedule, or below, heaters shall be supplied with the following thermostats:
  - Pilot duty single stage room thermostat
  - Pilot duty digital display single stage room thermostat
  - Pilot duty two stage digital display room thermostat
  - Pilot duty two or three stage programmable with digital display room thermostat
  - Proportional electronic room thermostat
  - Pilot duty single stage duct thermostat
  - Pilot duty two stage duct thermostat
  - Proportional electronic duct thermostat with set point adjuster
  - Special inputs (135 ohms, 2200 ohms, 4-20 mA, 0-10 VDC)



# Custom Duct Heaters

## Finned Tubular Custom Heater – Sample Specification

A job specification can be prepared by using the following information. Simply darken the applicable circles. Material which is part of the basic specification has already been darkened. Additional copies of this specification guide are available from your local Indeeco representative.

- 1. Duct heaters shall be Indeeco:
  - Type TFXU Custom Slip-in Heater
  - Type TFZU Custom Flanged Heater
- 2. Approvals – Heaters and panelboards (if required) shall meet the requirements of the National Electrical Code and shall be listed by Underwriters Laboratories, for zero spacing between the duct and combustible surfaces, and for use with heat pumps, and air conditioning equipment.
- 3. Heating elements shall consist of coil, 80% nickel, 20% chromium, Grade A resistance wire, precisely centered in a 304 stainless steel tube filled with granular magnesium oxide. A stainless steel fin is to be helically wound onto the tube. Elements are to be furnished with mounting flanges, making them individually removable through the terminal box.
- 4. Heater frames and terminal boxes shall be corrosion resistant steel. Unless otherwise indicated, the terminal box shall be NEMA 1 construction and shall be provided with a hinged latching cover and multiple concentric knockouts for field wiring.
- 5. All heaters shall be furnished with triple overtemperature protection. A disc type and linear, automatic reset thermal cutout are included for primary overtemperature protection. All heaters must also be furnished with a linear type manual reset thermal cutout with backup contactors (as required). For secondary overtemperature protection, heat limiters or other fusible overtemperature devices are not acceptable.
- 6. Heaters shall be rated for the voltage, phase, and number of heating stages indicated in the schedule. All three-phase heaters shall have equal balanced three-phase stages. All internal wiring shall be stranded copper with 105°C insulation and shall be terminated in crimped connectors or box lugs.
- 7. Terminal blocks shall be provided for all field wiring and shall be sized for installation of 75°C copper wire rated in accordance with NEC requirements.
- 8. Heaters shall be furnished either with the Control Option specified in the schedule and described below or with the specific components listed in the schedule.
  - Option G – Thermal cutouts, airflow switch, contactors, fuses (if over 48 amps), control circuit transformer (where required) and built-in snap-acting door interlocked disconnect switch.
  - Option J – Thermal cutouts, airflow switch, PE switches, contactors (where required), fuses (if over 48 amps), control circuit transformer (as required), and built-in snap-acting door interlocked disconnect switch.
  - Option K – Thermal cutouts, airflow switch, contactors (where required), SCR (with step controller if heater draws over 96 amps three-phase or 192 amps single-phase), fuses (if over 48 amps), control circuit transformer (where required) and built-in, snap-acting, door interlocked disconnect switch.
- 9. When specified in the schedule, or below, heaters will be supplied with the following Special Features:
  - Airflow switch for negative pressure operation
  - Insulated terminal box
  - Dust-tight terminal box
  - Special terminal box construction
    - NEMA 1 ◦ UL3R ◦ NEMA 12 ◦ NEMA 4 ◦ NEMA 4X
  - Stainless steel frame and terminal box
  - Upgraded element sheath material
    - 316SS ◦ Monel
  - Aluminized steel frame and terminal box
  - Insulated duct construction for slip-in heaters
  - Unheated section
  - Controls mounted in remote panelboard
    - NEMA 1 ◦ UL3R ◦ NEMA 12 ◦ NEMA 4 ◦ NEMA 4X
  - Deletion of transformer
  - Deletion of transformer and contactor
  - Transformer primary fusing (standard for Class I)
  - Transformer secondary fusing (Class II)
  - Additional user control circuit voltage (specify user VA)
  - Deletion of disconnect switch
  - Fused disconnect switch ( $\leq 48$  amps)
  - Fusing for heaters rated 48 amps or less)
  - “Low Airflow” pilot light
  - “Heater On” pilot light
  - “Overtemperature” pilot light
  - Each “Stage On” pilot light(s)
  - Fan relay (instead of airflow switch)
  - Fan relay (in addition to airflow switch)
  - Remote enable heater operation
  - Step controller
  - Built-in PE transducer
- 10. When specified in the schedule, or below, heaters shall be supplied with the following thermostats:
  - Pilot duty single stage room thermostat
  - Pilot duty digital display single stage room thermostat
  - Pilot duty two stage digital room thermostat
  - Pilot duty two or three stage programmable with digital display room thermostat
  - Proportional electronic room thermostat
  - Pilot duty single stage duct thermostat
  - Pilot duty two stage duct thermostat
  - Proportional electronic duct thermostat with set point adjuster
  - Special inputs (135 ohms, 2200 ohms, 4-20 mA, 0-10 VDC)

\*Indeeco has higher SCCR (short circuit current ratings) available for duct heaters up to 100kA. An optional fused disconnect switch with 100KAIC rating is also an option for our heaters. Please contact your factory representative for more information.

# Explosion-proof Duct Heaters

## Safety

Indeeco explosion-proof ULTRA-SAFE™ and EP2 duct heaters are cCSA<sub>us</sub> Approved T3, 392 °F (200 °C). The ULTRA-SAFE™ duct heater has the only standard product offering and features the industry's lowest ignition temperature code rating, T3C, 320°F (160°C).

## Experience

This catalog represents more than 85 years experience in industrial electric heating, our specialty since Indeeco was founded in 1929. Indeeco has more than 65 years experience with forced air comfort heating for hazardous locations.

## Complete Product Line

- Industry's most comprehensive product line of space heating equipment.
- Ratings up to 750 KW and 600 volts.
- Widest selection of built-in controls.

## Applications

Indeeco Duct Heaters provide a clean, safe source of electric heat for comfort heating and freeze protection in hazardous locations where specific explosive gases or dusts are present, and environments where moisture and corrosion exist.

## Use of Electric Heaters in Hazardous Areas

Electric heating equipment can be economically designed and safely used in hazardous areas, if the following special requirements are kept in mind.

1. The surface temperature of the electric heating equipment cannot exceed the ignition temperature of the hazardous atmosphere. To insure that the proper heater has been selected, it is essential that the correct NEC Ignition Temperature Code be specified (see **Table XVI**). If the Temperature Code selected is too high, the electric heating system may operate above the ignition point of the application, creating a potentially hazardous condition.
2. All arc and spark producing control devices must be isolated from the hazardous atmosphere. If it is not economically feasible to locate the control devices in a non-hazardous area, they must be housed in an enclosure that will withstand the pressure of a potential explosion from within the enclosure.
3. All electrical supply connections must be made according to the latest NEC and local code requirements for hazardous locations. This includes the requirement that conduit entering the enclosures must be provided with seals at the enclosure.

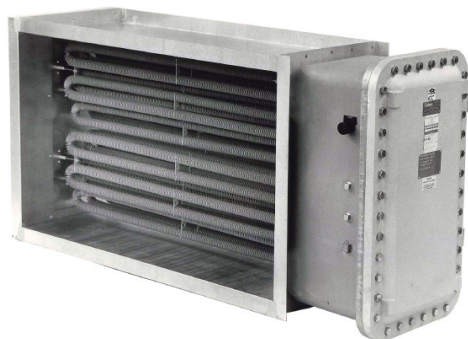

# Explosion-proof Duct Heaters

Hazardous locations are those areas where a potential for explosion and fire exists due to the presence of flammable gases, vapors, pulverized dusts, or ignitable fibers in the atmosphere. Hazardous locations are created from the normal processing of volatile chemicals, gases, coal, grains, etc., or from the accidental failure of storage systems for these materials.

Both people and equipment in hazardous locations can be heated safely and economically with electric heat. Electric heating is typically much less expensive to install and maintain than comparable hot water or remote oil or gas fired heating systems.

**Table XVI**

**Ignition Temperature for Gases, Vapors**

Maximum Surface Temperature of Heater		Ignition Temperature Code	
°C	°F	NEC 500	NEC 505
450	842	T1	T1
300	572	T2	T2
280	536	T2A	T3
260	500	T2B	
230	446	T2C	
215	419	T2D	
200	392	T3	T4
180	356	T3A	
165	329	T3B	
160	320	T3C	

\*All electrical equipment is designed not to exceed the ignition temperature of the hazardous atmosphere. The maximum surface temperature for electric heaters is defined by the NEC for each class as indicated above.

## National Electrical Code Classification

Articles 500 through 516 of the National Electrical Code deal with the definition of hazardous areas and the use or design of electrical equipment used in these locations. Electric heating equipment for hazardous areas is specified based on the NEC 500 Class, Division, Group, and Ignition Temperature. e.g. Class I, Division 1, Group C, T3C for gases, vapors, mists NEC 505 Area Classification, Symbol of Origin, Type of Protection, Material Group and Temperature Classification e.g. Class I Zone 0, AEx, ia, IIC, T6 and for dust NEC 506 Zone, Symbol, Protection, Group, Maximum surface temperature e.g. Zone 21 AEx, ia, IIIB, T180 C.

## Class

Hazardous locations are divided into the three general classes of vapors/gases, dusts, and fibers.

**Class I** – Locations where the potential for explosion and fire exists due to the presence of flammable gases or vapors in the air. Typical Class I locations include: oil or natural gas drilling rigs, petroleum refining or pumping facilities, petrochemical plants, wastewater/ sewage treatment plants, solvent extraction plants, paint spraying booths, locations where open tanks or vats of combustible liquids are present, and storage areas for flammable materials.

**Class II** – Locations where the potential for explosion exists because of finely pulverized flammable dusts suspended in the atmosphere. Typical locations would include coal fired power plants, coal preparation/coal handling facilities, coal mines, grain elevators, flour and feed mills, packaging and handling of pulverized sugar, processing and storage of magnesium and aluminum powder.

**Class III** – This third classification is primarily a fire hazard where fibers or flyings suspended in the air create a hazard. This would include small pieces of thread like fiber, sawdust, lint, etc. Typical applications would include: textile mills, woodworking plants, cotton gins and cotton seed mills, and flax producing plants.

## Division

Class I, Class II, and Class III areas are further defined in terms of when the hazard occurs. Division 1 and Division 2 occurrences are summarized below:

**Division 1** – If the hazard is expected to be present under normal conditions, such as in a production or processing facility, the occurrence is designated Division 1. The hazardous atmosphere may be present continuously, intermittently, periodically, or during normal repair or maintenance operations. Division 1 occurrences also include locations where a breakdown in the operations of processing equipment results in the release of hazardous vapors.

**Division 2** – If the hazardous material is normally expected to be contained within a closed area, system or container and would enter the ambient atmosphere only under an abnormal failure, then it is referred to as a Division 2 occurrence.

Flamable Medium	Hazardous Locations	Classification	
		NEC 500	NEC 505 & 506
Gases, Vapors, Mists	Always, temporary or often present	Class I, Division 1	Zone 0
	Occasionally present	Class I, Division 1	Zone 1
	Very seldom or only present for a short period of time	Class I, Division 2	Zone 2
Dusts	Always, temporarily or often present	Class II, III, Division 1	Zone 20
	Occasionally present	Class II, III Division 1	Zone 21
	Does not occur or only seldom for a short period	Class II, III, Division 2	Zone 22

# Explosion-proof Duct Heaters

## Group

The nature and explosive characteristics of the hazardous material is defined by the NEC group to which it is assigned.

**Class I** – Hazardous gas locations include chemicals and other materials that have been divided into four groups based on their ignition temperature and explosive characteristics. (Groups A, B, C and D)

**Class II** – Hazardous dust locations are divided into three groups based on their ignition temperature and electrical conductivity of the suspended particles.

**Group E** – Atmospheres containing metal dusts such as aluminum and magnesium.

**Group F** – Atmospheres containing coal, charcoal, or coke dusts.

**Group G** – Atmospheres with grain, flour, starch, combustible plastics, or chemical dusts.

**Class III** – Locations have no group definitions.

Table XVII

CLASS I - HAZARDOUS GAS ATMOSPHERES							CLASS I - HAZARDOUS GAS ATMOSPHERES								
Group NEC 500	Group NEC 505	Material	Ignition Temp. °F °C		NEC 500 Code	NEC 505 Code	Group NEC 500	Group NEC 505	Material	Ignition Temp. °F °C		NEC 500 Code	NEC 505 Code		
A	IIC	Acetylene	581	305	T2	T1	D	IIA	Methyl Isobutyl Ketone	840	448	T2	T2		
B	IIB+H2	Acrolein (Inhibited)	428	220	T2D	T1			2-Methyl-1-Propanol (Isobutyl Alcohol)	780	415	T2	T2		
		Butadiene	788	420	T2	T1			Petroleum Naptha	550	288	T2A	T2		
		Ethylene Oxide	804	429	T2	T1			Pyridine	900	482	T1	T2		
		Hydrogen	932	500	T1	T1			Octanes	403	206	T3	T2		
		Propylene Oxide	840	449	T2	T1			Pentanes	500	260	T2B	T2		
		Propyl Nitrate	347	175	T3B	T4			1-Pentanol (Amyl Alcohol)	650	343	T2	T2		
C	IIB	Acetaldehyde	347	175	T3B	T4			Propane	842	450	T1	T2		
		Allyl Alcohol	713	378	T2	T4			1-Propanol (Propyl Alcohol)	775	412	T2	T2		
		Carbon Monoxide	1128	609	T1	T4			2-Propanol (Isopropyl Alcohol)	750	399	T2	T2		
		Cyclopropane	928	498	T1	T4			Propylene	851	455	T1	T2		
		Ethylene	842	450	T1	T4			Styrene	914	490	T1	T2		
		Hydrogen Cyanide	1000	538	T1	T4			Toluene	896	480	T1	T2		
		Hydrogen Sulfide	500	260	T2B	T4			Vinyl Acetate	756	402	T2	T2		
		2-Nitropropane	802	428	T2	T4			Vinyl Chloride	882	472	T1	T2		
Tetrahydrofuran	610	321	T2	T4	Xylenes	867- 984			463- 528	T1	T2				
D	IIA	Acetic Acid (Glacia)	867	463	T1	T4			CLASS II - HAZARDOUS DUST ATMOSPHERES						
		Acetone	869	465	T1	T4			Group NEC 500	Group NEC 505	Material	Ignition Temp. °F °C		NEC 500 Code	NEC 505 Code
		Ammonia, Anhydrous	1204	651	T1	T4			E	IIIC	Aluminum, A422 Flake	608	320	T2	T320°C
		Benzene	928	498	T1	T4					Calcium Silicide	1004	540	T1	T540°C
		Butane	550	287	T2A	T4	Manganese	464			240	T2C	T240°C		
		1-Butanol (Butyl Alcohol)	650	343	T2	T4	Magnesium, Grade B, Milled	806			430	T2	T430°C		
		2-Butanol (Secondary Butyl Alcohol)	761	405	T2	T4	F	IIIB	Charcoal	356	180	T3A	T180°C		
		Ethane	882	472	T1	T4			Coal, Kentucky Bituminous	356	180	T3A	T180°C		
		Ethanol (Ethyl Alcohol)	685	363	T2	T4			Coal, Pittsburgh Experimental	338	170	T3B	T170°C		
		Ethyl Acetate	800	427	T2	T4			Pitch, Petroleum	1166	630	T1	T630°C		
		Ethylene Dichloride	775	413	T2	T4	G	IIIB	Alkyl Ketone Dimer Sizing Compound	320	160	T3C	T160°C		
		Gasoline (56-60 Octane)	536	280	T2A	T4			Corn	482	250	T2C	T250°C		
		Gasoline (100 Octane)	853	456	T1	T4			Corn Starch, Modified	392	200	T3	T200°C		
		Heptanes	399	204	T3	T4			Polyurethane Foam, Fire Retardant	734	390	T2	T390°C		
		Hexanes	437	235	T2D	T4			Shellac	752	400	T2	T400°C		
		Isoprene	428	220	T2D	T4			Soy Flour	374	190	T3A	T190°C		
		Isopropyl Ether	830	443	T2	T4			Sugar, Powdered	698	370	T2	T370°C		
		Methane (Natural Gas)	900- 1170	482- 632	T1	T4			Sulfur	428	220	T2D	T220°C		
		Methanol (Methyl Alcohol)	867	454	T1	T4			Wheat	428	220	T2D	T220°C		
		3-Methyl-1-Butanol (Isoamyl Alcohol)	662	350	T2	T4			Wood Flour	500	260	T2B	T260°C		
		Methyl Ethyl Ketone	759	404	T2	T4									

The materials given are found in NEPA 497M, 1991 and NFPA 325, 1994.

# Explosion-proof Duct Heaters

## Engineering Information

National Electrical Code Requirements for Duct Heaters In addition to the general requirements for hazardous areas on pages 42 and 43, the NEC also requires that all duct heaters have built-in protection against low airflow, primary and secondary overtemperature protection, and overcurrent protection for heaters drawing more than 48 amps. These safety features are provided with all Indeeco explosion-proof duct heaters.

## Airflow Requirements

Airflow must be calculated to give the required temperature rise and to ensure sufficient airflow to prevent the thermal cutouts from tripping prematurely.

**Required air volume** to give the desired temperature rise for a given KW is determined by the formula:  $CFM = KW \times 3193 / \Delta T$  where CFM is airflow volume in Standard Cubic Feet per Minute and  $\Delta T$  is temperature rise in °F.

**Minimum air velocity** for safe operation is determined by dividing the heater KW by the cross-sectional duct area:  $KW/Sq. Ft. = KW / (W \times H / 144)$  where W and H are duct width and height in inches. For ULTRA-SAFE™ duct heaters, use the minimum W x H dimensions shown in the Heater Listing on page 48. Read the minimum velocity from the horizontal axis of Figure 72 for ULTRA-SAFE™ Duct Heater or Figure 73 for Series EP2 heaters.

**Airflow must be uniform** over the face of the heater, and must be horizontal for all but Custom Explosion-proof Duct Heaters.

Horizontal airflow direction is defined in Figure 71.

**Pressure drop** through the heater can be determined by using Figure 74 for the ULTRA-SAFE™ duct heater.

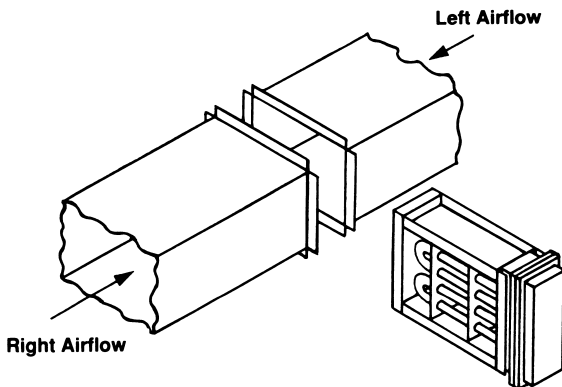

Figure 71.

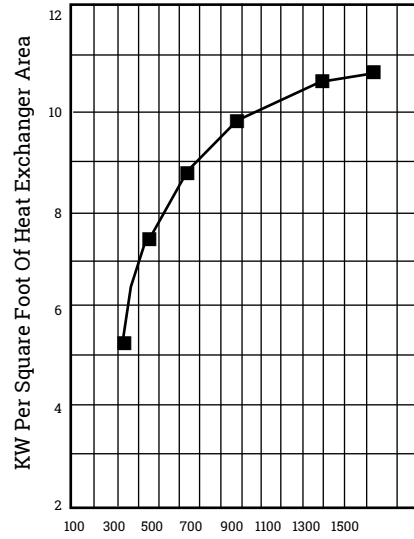

Figure 72.

Minimum air velocity required for ULTRA-SAFE™, feet per minute (meters per minute)

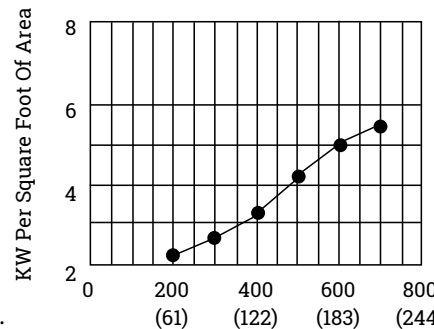

Figure 73.

Minimum air velocity required for EP2 feet per minute (meters per minute)

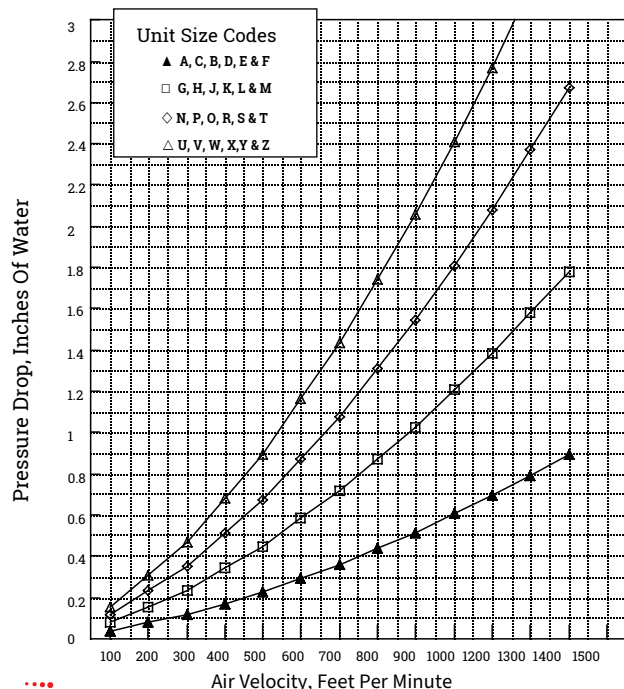

Figure 74.

ULTRA-SAFE™  
Pressure Drop Curve

# Explosion-proof Duct Heaters

Engineering developments at Indeeco have made electric duct heaters for hazardous locations readily available at affordable prices.

## ULTRA-SAFE™

- $\text{cCSA}_{\text{US}}$  Approved for virtually all Class I and Class II, Division 1 and 2 hazardous gas or dusty atmospheres
- Ignition temperatures as low as 320°F (160°C)
- Six standard sizes to fit a wide range of ducts
- Ratings up to 240 KW, 600 volts

## Series EP2

- $\text{cCSA}_{\text{US}}$  Approved for Class I, Division 2 locations where a hazardous gas is occasionally present
- Ignition temperatures as low as 392°F (200°C)
- For ducts up to 240" (610 cm) wide by 120" (305 cm) high
- Ratings up to 1000 KW, 600 volts

## Custom

- Non- $\text{cCSA}_{\text{US}}$  Approved for Class I and Class II, Division 1 and 2 hazardous gas or dusty atmospheres
- Wider range of sizes than available in the other two designs
- Vertical airflow
- Ratings up to 750 KW, 600 volts

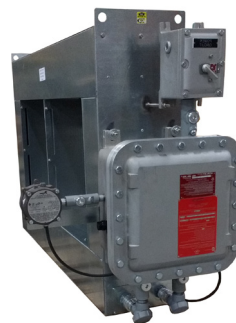

Figure 75. ULTRA-SAFE™ Explosion-proof Duct Heater



Figure 76. EP2 Explosion-proof Duct Heater

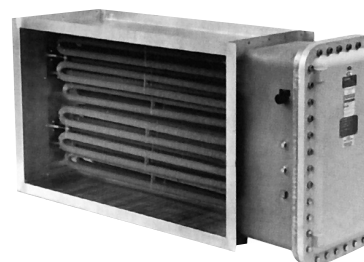

Figure 77. Custom Explosion-proof Duct Heater

Table XVIII

### Comparison Chart

Heater Type	KW and Control Range	Class and Division	NEC Ignition Temperature Code	Special Considerations
Ultra-Safe™ For hazardous gas or dust atmospheres. Fits ducts from 12"W x 12" H to 52"W x 35" H.	Up to 240 KW  Single stage or SCR Control	Class I, Divisions 1 and 2, Groups B, C and D  Class II, Divisions 1 and 2, Groups E, F and G	T3C 320 °F (160 °C)	<ul style="list-style-type: none"> <li>• Fastest delivery of the three designs</li> <li>• Available for outdoor or wet locations</li> <li>• Corrosion resistant construction available</li> <li>• Horizontal airflow only</li> <li>• Not approved for shipboard use</li> <li>• Flanged mounting</li> </ul>
Series EP2 For Division 2 hazardous gases (hazard exists only occasionally).	Up to 1000 KW  Multi-stage or SCR Control	Class I, Division 2, Groups C and D	T3 392 °F (200 °C)	<ul style="list-style-type: none"> <li>• Available for outdoor or wet locations</li> <li>• May be less expensive than ULTRA-SAFE™ for larger KW designs</li> <li>• Horizontal airflow only</li> <li>• Approved for shipboard use</li> <li>• Flanged mounting</li> </ul>
Custom Designed for each project. Not $\text{cCSA}_{\text{US}}$ Approved.	Up to 750 KW  Multi-stage or SCR Control	Class I, Divisions 1 and 2, Groups C and D  Class II, Divisions 1 and 2, Groups E, F and G	T1 842 °F (450 °C) through T3B 329 °F (165 °C)	<ul style="list-style-type: none"> <li>• Horizontal or vertical airflow</li> <li>• Slip-in or flanged mounting</li> <li>• For ducts smaller than 12" x 12"</li> <li>• Available for outdoor or wet locations</li> </ul>

# ULTRA-SAFE™ Explosion-proof Duct Heaters

## Standard Construction

**Heat Exchanger** has copper tubes with integral aluminum fins. Each unit undergoes hydrostatic testing at 350 psig, five times the pressure relief valve setting of 70 psig.

**Heat Transfer Fluid** is propylene glycol, a non-toxic, rust-inhibiting fluid that provides freeze protection to  $-40^{\circ}\text{F}$  ( $-40^{\circ}\text{C}$ ). Its high heat transfer rate at 70 psig makes the heat exchanger suitable for gases that ignite at temperatures as low as  $320^{\circ}\text{F}$  ( $160^{\circ}\text{C}$ ). Thus every ULTRA-SAFE™ heater is rated for Temperature Code T3C.

**Industrial Grade Heating Elements**, built by Indeeco, are .475" (1.21 cm) diameter to provide extra insulation between the coil and sheath for high voltage protection.

**Frame** is heavy gauge galvanized steel, fitted with lifting lugs to facilitate installation.

**Four Levels of Safety** are provided on every heater: automatic and manual reset thermal cutouts, airflow interlock, and pressure relief valve.

Two thermal cutouts limit the heat transfer fluid temperature, assuring thermal safety. The automatic reset operates a "primary" magnetic contactor. The manual reset operates a separate backup magnetic contactor. If either cutout opens, the entire heater is de-energized.

A fan relay, acting as an airflow interlock, prevents the heater from being energized unless the fan starter is on.

The pressure relief valve on the heat exchanger opens only if the thermal cutout system fails to prevent excessive temperatures.

**Standard Built-in Control Package** includes the following components mounted in a cast aluminum explosion-proof enclosure:

- De-energizing control and back-up magnetic contactors.
- 24V control circuit transformer.
- Fan relay, supplied with 24V or 120V holding coil to match the fan starter coil voltage.
- Terminal blocks for field power and control wiring.
- Grounding terminal.
- Supplemental fusing for heaters drawing more than 48 amps.

## Installation

Complete installation instructions are furnished with each heater. Following are some guidelines:

- The heater must be securely attached to external duct flanges.
- The heater must be adequately supported. If the duct flanges will not afford enough support, overhead hangers attached to the lifting lugs may be used for additional support.
- Each heater is suitable for a variety of duct sizes. See **Table XIX** on page 48 for maximum and minimum dimensions. Note that duct height and width can vary independently.
- Airflow must be horizontal. See page 44 for airflow requirements.

Attach hanger rods to structure capable of supporting the weight of the heater.

Ensure attachment allows for height adjustment so that heater is level along both axis.

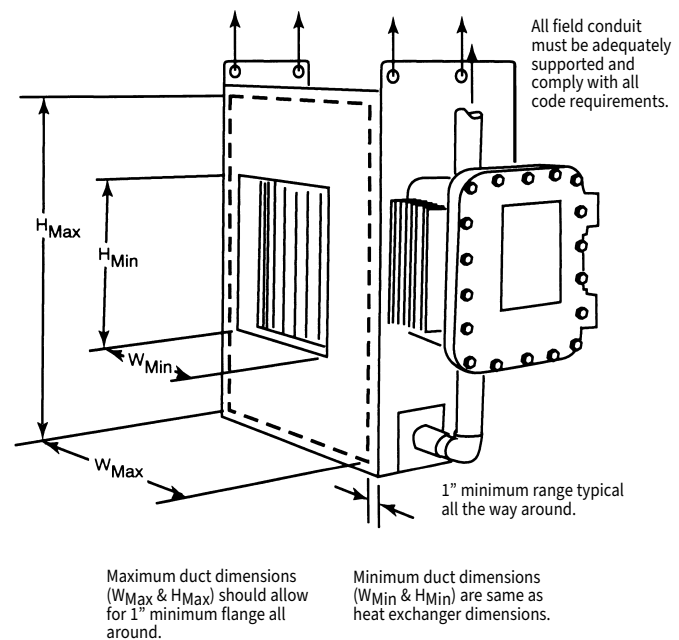

Figure 78. ULTRA-SAFE™ Mounting Configuration



Classes I and II, Division 1 and 2  
Groups B, C, D, F and G  
Temperature Code  
T3C,  $320^{\circ}\text{F}$  ( $160^{\circ}\text{C}$ )

Ratings Available

- Up to 240 KW
- Up to 600V

**INDEECO**  
www.indeeco.com  
800-243-8162

# ULTRA-SAFE™ Explosion-proof Duct Heaters

## Temperature Control

**Single Stage Control** – For many lower KW applications, single stage on/off control is adequate. For higher KW ratings, solid-state SCR control is recommended.

**Solid-State SCR Control** – When temperature must be controlled precisely, or for larger KW heaters, built-in SCR's manufactured by Indeco are recommended. They are furnished with field-selected inputs of 2200 or 135 ohms, 0-10 VDC, or 4-20

mA. SCR's have zero-cross firing to eliminate radio frequency interference.

To meet  $c_{CSA_{US}}$  requirements, multi-unit designs (up to four heating units in series) also have controls set at 80°F (27°C) to limit the inlet air temperature to all but the inlet unit. These limit controls prevent excessive temperatures at the heater outlet as the inlet air temperature rises.

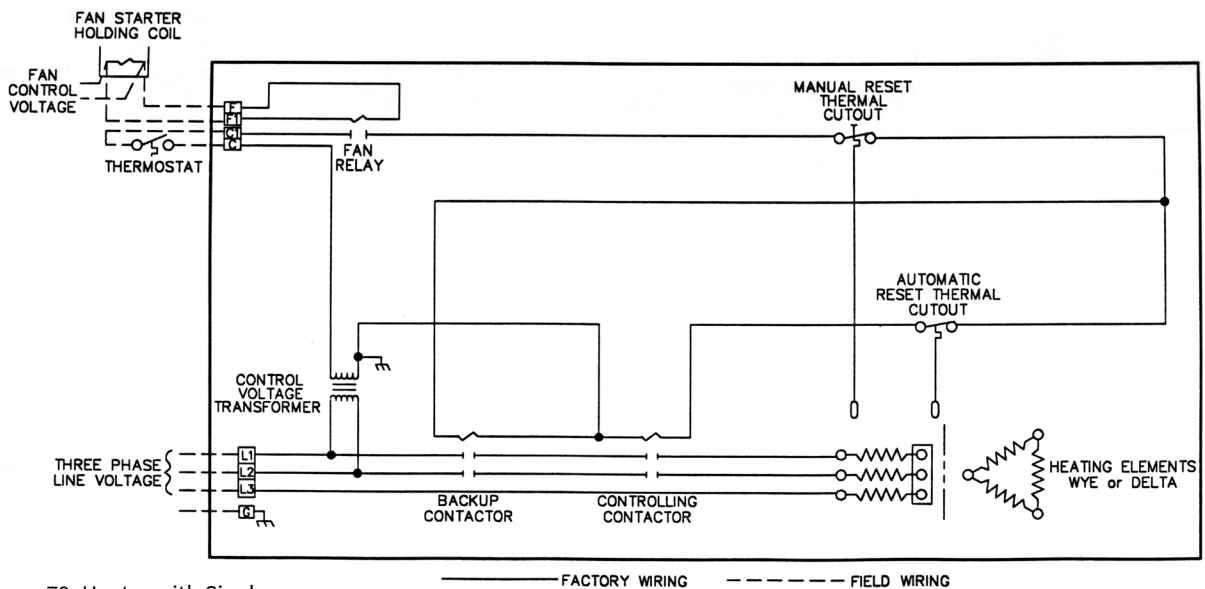

Figure 79. Heater with Single Stage Control

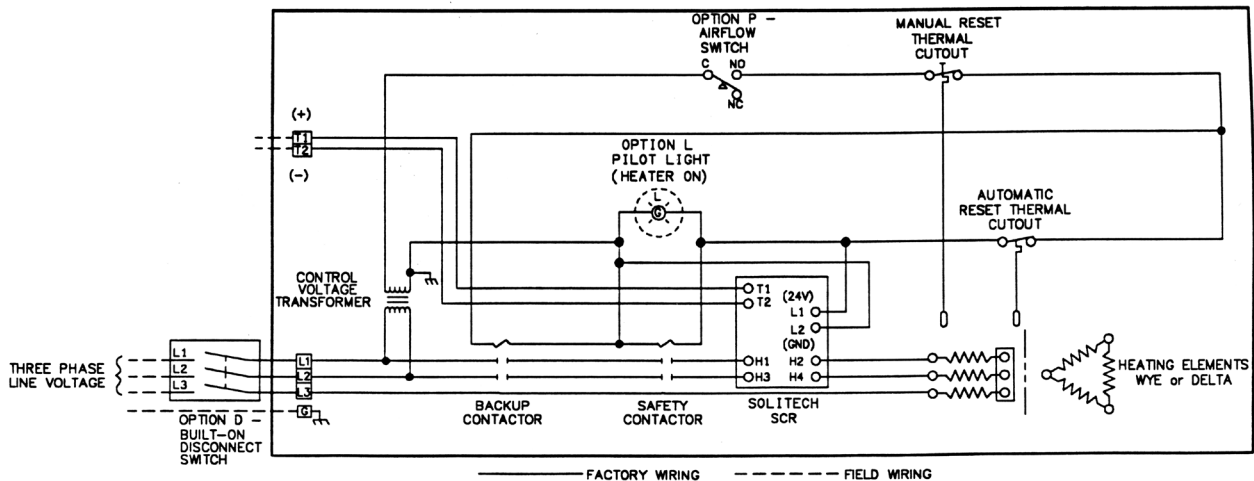

Figure 80. Heater with SCR Control and Options D, L and P



# ULTRA-SAFE™ Explosion-proof Duct Heaters

Table XIX

Standard Heater Listing

Catalog Number	Unit Size		KW Range		Inside Duct Dimensions (4) - in (cm)		Depth (3) in (cm)	Weight (3) lb (kg)		
	Code	Figure	Min.	Max.	Min. (2) W X H	Max. (1) W X H				
227F30A	A	81	3	10	12 X 12 (30.5 X 30.5)	18 X 24 (45.7 X 61)	8 (20)	130 (59)		
227F30G	G		6	20			16 (41)	260 (118)		
227F30N	N		9	30			24 (61)	680 (208)		
227F30U	U		12	40			32 (81)	710 (332)		
227F30B	B		3	20	16.5 X 16 (41.9 X 40.6)	22.5 X 28 (71 X 71)	12 (31)	150 (68)		
227F30H	H		6	40			24 (61)	300 (136)		
227F30P	P		9	60			36 (91)	730 (331)		
227F30V	V		12	80			48 (122)	770 (349)		
227F30C	C		10	30	21 X 21 (53.3 X 53.3)	27 X 35 (69 X 89)	12 (31)	200 (91)		
227F30J	J		20	60			24 (61)	400 (181)		
227F30Q	Q		30	90			36 (91)	860 (390)		
227F30W	W		40	120			48 (122)	940 (426)		
227F30D	D	82	6	20			24 X 12 (61 X 30.5)	34 X 24 (86 X 61)	8 (20)	260 (118)
227F30K	K		12	40					16 (41)	470 (213)
227F30R	R		18	60	24 (61)	970 (440)				
227F30X	X		24	80	52 (32)	1090 (494)				
227F30E	E		6	40	33 X 16 (83.8 X 40.6)	43 X 28 (109 X 71)	12 (30)	300 (136)		
227F30L	L		12	80			24 (61)	550 (249)		
227F30S	S		18	120			36 (91)	1080 (490)		
227F30Y	Y		24	160			48 (122)	1240 (562)		
227F30F	F		20	60	42 X 21 (106.7 X 53.3)	52 X 35 (132 X 89)	12 (31)	390 (177)		
227F30M	M		40	120			24 (61)	730 (331)		
227F30T	T		60	180			36 (91)	1350 (612)		
227F30Z	Z		80	240			48 (122)	1600 (726)		

- (1) Consult factory for availability of other maximum inside duct dimensions.
- (2) Use only Minimum W x H dimensions for minimum air velocity calculations (see page 44).
- (3) Depth and weights shown for catalog listed KW ratings. They will be greater for larger KW and non-catalog designs.
- (4) Duct height and width can vary independently of minimum and maximum dimensions.

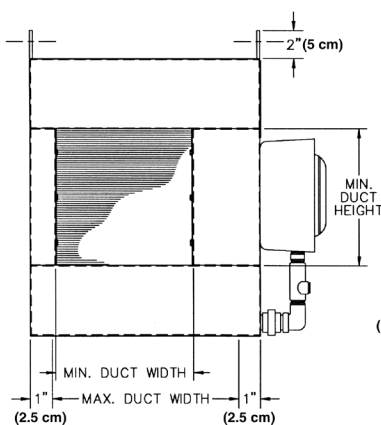

Figure 81.  
1 Heat Exchanger Module

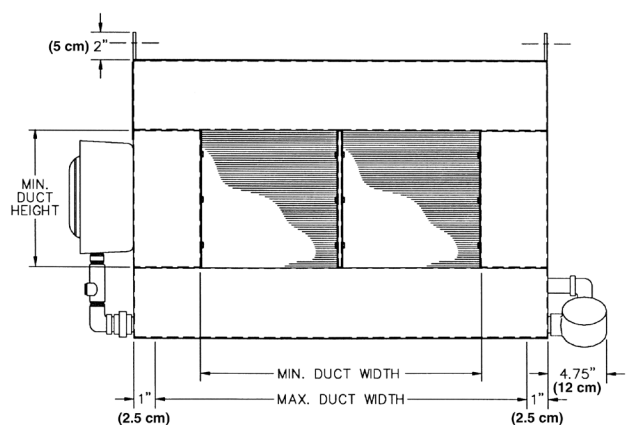
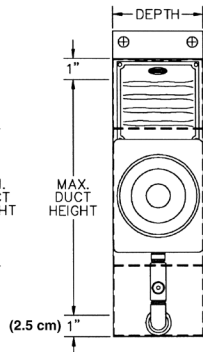

Figure 82.  
2 Heat Exchanger Modules

# ULTRA-SAFE™

## Explosion-proof Duct Heaters

**Table XX**

**Custom Options**

Option	Description	Code
Corrosion Resistant Construction	Stainless frame, coated heat exchanger, epoxy-coated component enclosure, conduit and fittings.	C
Built-On Disconnect Switch	To meet NEC requirement for a disconnect at or within sight of the heater. (Not available for outdoor, washdown or Groups B, E, F, G)	D
Built-on Airflow Switch	An explosion-proof differential pressure switch replaces the fan relay. Use only for positive pressure inside the duct. (Not available for outdoor, washdown or Group B).	P
Supplementary Fusing	For heaters drawing 48 amps or less. Fusing is standard above 48 amps.	F
“Warning” Pilot Light	Red light to indicate when a thermal cutout or airflow interlock has tripped.	K
“Heater On” Pilot Light	Green light indicates when there is power to the heater.	L
Disconnecting Magnetic Contactors	Contactors that break all ungrounded lines replace standard de-energizing contactors.	M
120 Volt Control Circuit	A 120V control transformer with fused primaries replaces the standard 24V transformer. (Not available with solid-state SCR control.)	V
Type 4 Component Enclosure	Explosion-proof box is gasketed for outdoor or wet locations.	G
Group B Construction	For Class I, Group B areas. Heater will be rated for Classes I and II; Divisions 1 and 2; Groups B, C, D, E, F and G.	Z

**Thermostats**

Catalog Number	Switch Type	Ratings	Corrosion Resistant	Agency Approvals	Type	Tamper-proof	Temperature Range °F
1007018	2,200 Ohm Thermistor	Class I, Division 1, Group B,C&D, Class II, Division 1, Group E,F&G NEMA 4,7 (1)	No	cCSA <sub>us</sub>	Wall Mounted	Yes (2)	40 - 120
1018806		Class I, Division 1, Group B,C&D, Class II, Division 1, Group E,F&G NEMA 4,7 (1)	Yes	cCSA <sub>us</sub>	Wall Mounted	Yes (2)	40 - 120
C324-056		Class I, Division 1, Group C&D, Class II, Division 1, Group E,F&G NEMA 7	No	No	Wall Mounted	No	0 - 100
810-102655 Adjuster and 810-108449 Sensor		Class I, Division 1, Group C&D, Class II, Division 1, Group E,F&G NEMA 7	No	No	Wall Mounted Adjuster	No	0 - 100
		Class I, Division 1, Group C&D, Class II, Division 1, Group E,F&G NEMA 4,7 (1)			Duct Sensor		

(1) Enclosure gasketed and suitable for outdoor use.

(2) Internal set point adjuster requires cover to be moved to change setting.

# ULTRA-SAFE™ Explosion-proof Duct Heaters

## How to Order

1. **Catalog No. or Size** – Specify Catalog Number from **Table XIX** on page 48.
2. **KW Rating** – Up to the maximum shown in **Table XIX**.
3. **Heater Voltage and Phase**
4. **Temperature Control** – Single Stage or SCR Control. If SCR Control, specify input signal.
5. **Fan Relay Voltage** – Specify 24 or 120 volt to match fan starter holding coil voltage.
6. **Airflow Direction** – Horizontal Right-Hand or Left-Hand airflow, as defined on page 44.
7. **Maximum Inlet Air Temperature** – Maximum of 80° F (27° C). If inlet air will be higher, consult factory.
8. **Options** – Select from ULTRA-SAFE™ Custom Option codes in **Table XX**.

## Sample Specification

A sample specification can be prepared by using the following information. A circle has been supplied so that you may darken those sections which you require. Material which is part of the standard ULTRA-SAFE™ Explosion-proof Duct Heater specification has already been darkened.

- 1. Electric explosion-proof duct heaters shall be Indeeco ULTRA-SAFE™ Series, of the KW rating, voltage, phase, duct size and airflow direction specified in the schedule. They shall be  $\text{CSA}_{us}$  Approved for:
  - Class I, Divisions 1 and 2, Groups C and D; Class II, Divisions 1 and 2, Groups E, F, and G Ignition Temperature Code No. T3C, 320°F (160°C).
  - Class I, Divisions 1 and 2, Groups B, C, and D; Class II, Divisions 1 and 2, Groups E, F, and G Ignition Temperature Code No. T3C, 320°F (160°C).
- 2. Duct heaters shall have automatic and manual reset thermal cutouts for redundant overtemperature protection, fan relay for airflow interlock, de-energizing controlling and backup

magnetic contactors, 24 volt control circuit transformer, terminal blocks for field wiring and supplementary fusing for heaters over 48 amps. Controls shall be housed in a NEMA 7, 9 cast aluminum enclosure.

- 3. The heat exchanger shall be liquid-to-air design, utilizing a copper tube core with integral aluminum fins. Nontoxic, inhibited, propylene glycol heat transfer fluid shall be used that provides freeze protection down to -40°F (-40°C). Pressure relief valve setting to be 70 psig. The heat exchanger shall include industrial grade Indeeco electric heating elements.
- 4. Duct heaters shall be furnished with the control option indicated below (select one):
  - Single stage on/off control with field installed thermostat.
  - Solid-state control with built-in zero-cross switching SCR and field installed thermostat.
- 5. The following options are to be included:
  - Corrosion resistant stainless steel construction with iridite coated heat exchanger, epoxy coated component enclosure terminal box, conduit and fittings.
  - Built-on disconnect switch (not available for outdoor, washdown or Group B, E, F constructions).
  - Supplementary fusing for heaters drawing less than 48 amps.
  - Warning pilot light to indicate overtemperature or no airflow.
  - “Heater On” pilot light to indicate power to the heater.
  - Disconnecting magnetic contactors.
  - Built-on airflow switch in place of the fan relay (not available for outdoor, washdown or Group B construction).
  - 120 volt transformer in place of 24 volt transformer (not available with solid-state SCR control).
  - Type 4 component enclosure gasketed control box for wet locations.

## Typical ULTRA-SAFE™ Duct Heater Schedule

Tag No.	KW	Supply Line		Stages	Duct Dimensions (Inches)		Special Features
		Volts	Phase		W (Width)	H (Height)	
DH1	10	480	3	1	18	12	Built-on disconnect switch
DH2	15	480	3	1	36	18	Corrosion resistant construction
DH3	75	480	3	1	48	24	

# SERIES EP2 Explosion-proof Duct Heaters

## Standard Construction

**Galvanized Sheet Metal Frame** includes external flanges for field mounting and an element terminal box. Terminals are factory-connected to control safety components in an integral cast aluminum explosion-proof box.

**Three Levels of Safety** are provided on every heater: automatic and manual reset thermal cutouts, plus a fan interlock relay.

The automatic reset cutout, operating through the temperature control system, is the primary protector. The manual reset operates a separate backup magnetic contactor, independent of the temperature control system. The fan interlock relay prevents the heater from being energized, unless the fan starter is on.

**Standard Built-in Control Package** includes the following components mounted in a cast aluminum explosion-proof enclosure:

- De-energizing control and backup magnetic contactors.
- 24 volt control circuit transformer.
- Fan relay for heater/fan airflow interlock. Supplied with 120V or 24V coil to match the fan starter.
- Terminal blocks for field power and control wiring.
- Grounding terminal.
- Supplemental fusing for heaters drawing more than 48 amps.

**Industrial Grade Heating Elements**, built by Indeeco, are .475" (1.21 cm) diameter to provide extra insulation between the coil and sheath for high voltage protection. Stainless steel fins are helically wound onto the stainless steel sheath.

## Control Options

Two standard control options are available:

**Staged Control** – Either single or multi-staged through a step controller, which may be built-in or remotely mounted. Each three-phase stage has a multiple of three elements to balance the electrical load.

**Solid-State SCR Control** – When temperature must be controlled precisely, built-in SCR's are recommended. They are furnished with field-selected inputs of 2200 ohms, 135 ohms, 0-10 VDC, or 4-20 mA. SCR's have zero-cross firing to eliminate radio frequency interference.

## Installation

Complete installation instructions are furnished with each heater. The following are some guidelines:

- The heater must be attached to external duct flanges.
- The heater must be adequately supported. If the duct flanges will not afford enough support, use overhead hangers for additional support.
- Airflow must be horizontal. See page 44 for airflow requirements.



Figure 83. Series EP2 Explosion-proof Duct Heaters

Class I, Division 2  
Groups C and D  
Temperature Code  
T3, 392°F (200°C)

Ratings Available  
• Up to 240 KW  
• Up to 600V



# SERIES EP2

## Explosion-proof Duct Heaters

Table XXI

Custom Options

Option	Description	Code
Built-in Step Controller	For two through ten heating stages. Input is field-selected at 2200 ohms, 135 ohm, 0-10 VDCs, or 4-20 mA.	B
Built-On Disconnect Switch	To meet NEC requirement for a disconnect at or within sight of the heater. (Not available for outdoor or washdown)	D
Built-on Airflow Switch	An explosion-proof differential pressure switch replaces the fan relay. Use only for positive pressure inside the duct. (Not available for outdoor or washdown).	P
Supplementary Fusing	For heaters drawing 48 amps or less. Fusing is standard above 48 amps.	F
“Warning” Pilot Light	Red light to indicate when a thermal cutout or airflow interlock has tripped.	K
“Heater On” Pilot Light	Green light indicates when there is power to the heater.	L
Disconnecting Magnetic Contactors	Contactors that break all ungrounded lines replace standard de-energizing contactors.	M
120 Volt Control Circuit	A 120V control transformer with fused primaries replaces the standard 24V transformer.	V
Type 4 Component Enclosure	Explosion-proof box is gasketed for outdoor or wet locations	G

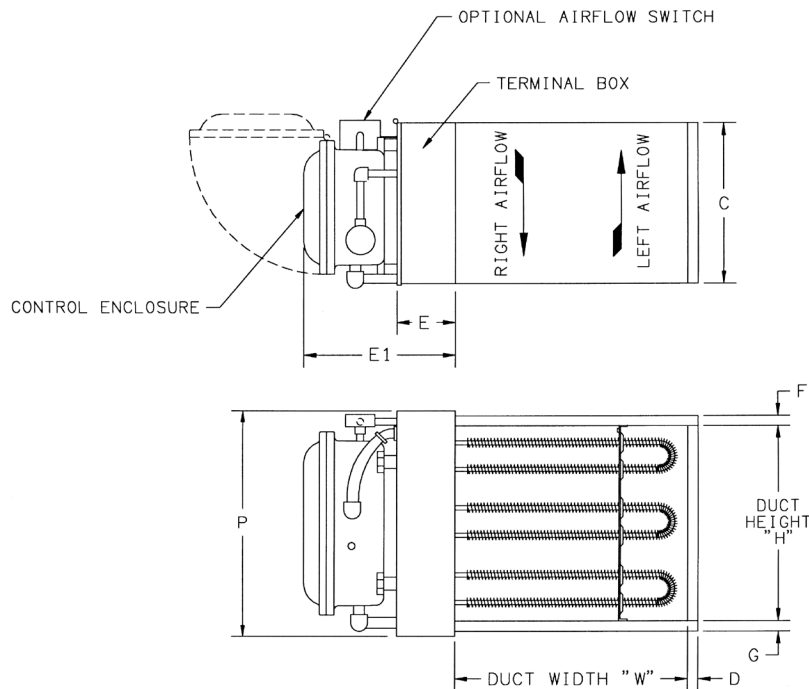

Figure 84. Dimensional Drawing for EP2

# SERIES EP2

## Explosion-proof Duct Heaters

### How to Order

1. **Inside Duct Dimensions** – Width (W) by Height (H) per Dimensional Drawing on page 52. Maximum size 240” (610 cm) x 120” (305 cm). Other dimensions will be shown on certified print.
2. **KW Rating** – Up to 1000 KW.
3. **Heater Voltage and Phase**
4. **Temperature Control** – Staged or SCR control. If staged, specify number of stages (one through ten). If SCR control, specify input signal.
5. **Fan Relay Voltage** – Specify 24 or 120 volt to match fan starter holding coil voltage.
6. **Airflow Direction** – Horizontal right-hand or left-hand airflow, as defined on page 44.
7. **Airflow Volume** – Minimum flow in SCFM (Standard Cubic Feet per Minute) over the heater.
8. **Maximum Inlet Air Temperature** – Maximum of 80°F (27°C). If inlet air will be higher, consult factory.
9. **Options** – Select from EP2 Custom Option codes in **Table XXI**.

- 2. Duct heaters shall have automatic and manual reset thermal cutouts for redundant overtemperature protection, fan relay for airflow interlock, de-energizing controlling and backup magnetic contactors, 24 volt control circuit transformer, terminal blocks for field wiring and supplementary fusing for heaters over 48 amps. Controls shall be housed in a NEMA 7, 9 cast aluminum enclosure.
- 3. Duct heaters shall consist of industrial grade Indeeco stainless steel finned tubular electric heating elements mounted in a heavy-gauge galvanized steel frame.
- 4. Duct heaters shall be furnished with the control option indicated below (select one):
  - Single stage on/off control with field installed thermostat.
  - Multi-staged control with built-in step controller and field installed thermostat.
  - Solid-state control with built-in zero-cross switching SCR and field installed thermostat.
- 5. The following options are to be included:
  - Built-on disconnect switch.
  - Built-on airflow switch in place of the fan relay.
  - Supplementary fusing for heaters drawing less than 48 amps.
  - “Warning” pilot light to indicate overtemperature or no airflow.
  - “Heater On” pilot light to indicate power to the heater.
  - Disconnecting magnetic contactors.
  - 120 volt transformer in place of 24 volt transformer.
  - NEMA 4, 7, 9 gasketed control box for wet locations.

### Sample Specification

A sample specification can be prepared by using the following information. A circle has been supplied so that you may darken those sections which you require. Material which is part of the standard Series EP2 Explosion-proof Duct Heater specification has already been darkened.

- 1. Electric explosion-proof duct heaters shall be Indeeco Series EP2 of the KW rating, voltage, phase, duct size and airflow direction specified in the schedule. They shall be  $c_{CSA}_{US}$  Approved for:
  - Class I, Division 2, Groups C and D, Ignition Temperature Code T3, 392°F (200°C)

### Typical Series EP2 Duct Heater Schedule

Tag No.	KW	Supply Line		Stages	Duct Dimensions (Inches)		Special Features
		Volts	Phase		W (Width)	H (Height)	
DH1	3	480	3	2	24	12	Built-on disconnect switch
DH2	10	480	3	3	36	18	
DH3	15	480	3	5	72	24	Warning pilot light

# Custom Explosion-proof Duct Heaters

## Construction

Heaters are generally constructed per Series EP2 (see page 57), except that element terminals as well as control components are built into a single cast aluminum explosion-proof enclosure.

**Frame** – Sized to fit the duct. Standard flanged design recommended to support heater weight. Slip-in also available, if necessary, to match other equipment. Galvanized steel standard; stainless steel optional.

**Control Enclosure** – NEMA 7, 9 cast aluminum box with hinged cover houses controls and element terminals. Weatherproof construction optional.

**Heating Elements** – Heavy wall, large diameter stainless steel finned tubular elements, individually removable for servicing.

**SCR Temperature Control** – SCR's with zero-cross firing provide precise proportional control. SCR's also minimize element operating temperatures for extra safety. Optional on/off single or multi-stage control also available.

**Overtemperature Protection** – Thermocouple controllers measure element sheath temperature.

- Automatic reset control resets when temperature drops to a safe level.
- Manual reset control, with external button, provides back-up protection.

**Fuses** – Individual circuit fusing for heaters drawing over 48 amps to meet NEC requirements.

**Airflow Interlock** – Fan relay prevents heater operation, unless fan is energized. Optional built-in or remote explosion-proof airflow switch can be provided.

**Magnetic Contactors** – Furnished as required for temperature and safety controls.

**Control Transformer** – Furnished as standard with fusing as required.

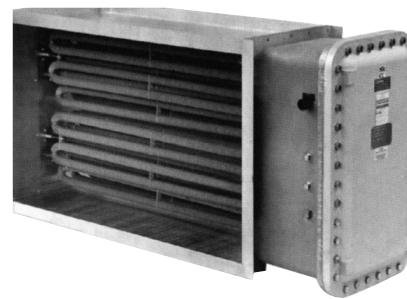

Figure 85. Custom Duct Heater



Figure 86 Control Enclosure

Class I, Division 1 and 2  
Groups C and D

Class II, Divisions 1 and 2  
Groups E, F and G

Although built to hazardous safety standards, these heaters are not  $cCSA_{us}$  Approved.

# Custom Explosion-proof Duct Heaters

## How to Order

1. **Construction Type** – Standard flanged or optional slip-in. See Figures 87 and 88.
2. **Electrical Ratings** – Line voltage, KW, Phase and Control Voltage.
3. **Inside Duct Dimensions** – Width and Height.
4. **Temperature Control** – Staged or SCR Control. If staged, specify number of stages (one through ten). If SCR control, specify input signal.
5. **Airflow Direction** –
  - Horizontal (Right or Left).
  - Vertical (Up or Down).
6. **Airflow Volume** – Minimum flow in SCFM (Standard Cubic Feet per Minute) over the heater.
7. **Maximum Inlet Air Temperature** – Maximum of 80°F (27°C). If inlet air will be higher, consult factory.
8. **Classification of Hazardous Area** – Class, Group, Ignition Temperature and NEC I.D. Code No.
9. **Options** – Select from EP2 Custom Option codes in **Table XXI** on page 52.

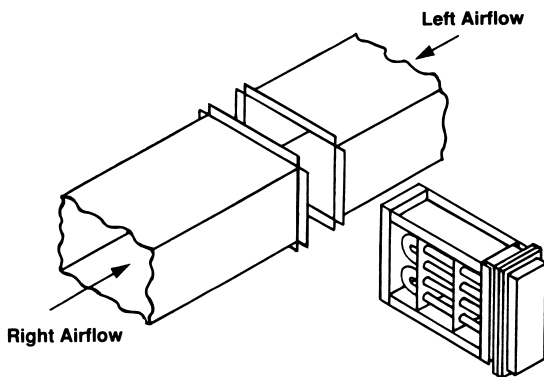

Figure 87. Standard Flanged Heater Installation

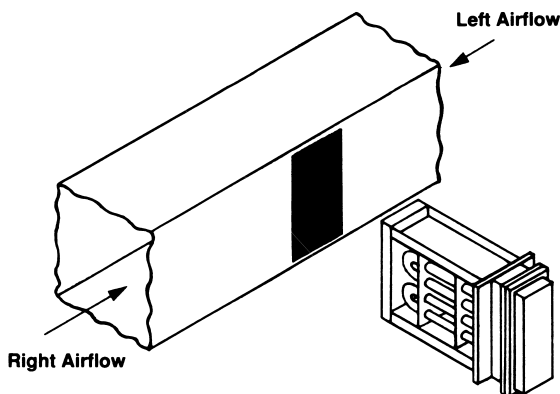

Figure 88. Optional Slip-in Heater Installation

## Sample Specification

A sample specification can be prepared by using the following information. A circle has been supplied so that you may darken those sections which you require. Material which is part of the standard Custom Explosion-proof Duct Heater specification has already been darkened.

- 1. Electric explosion-proof duct heaters shall be Indeeco custom explosion-proof, the KW rating, voltage, phase, duct size, construction type and airflow direction specified in the schedule. They shall be approved for:
  - Class I, Divisions 1 and 2, Groups C and D, and NEC Ignition Temperature I.D. Code Number \_\_\_\_\_ (please specify).
  - Class II, Divisions 1 and 2, Groups E, F, and G, and NEC Ignition Temperature I.D. Code Number \_\_\_\_\_ (please specify).
- 2. Duct heaters shall have automatic and manual reset thermal cutouts for redundant overtemperature protection, fan relay for airflow interlock, de-energizing controlling and backup magnetic contactors, 120 volt control circuit transformer, terminal blocks for field wiring and supplementary fusing for heaters over 48 amps. Controls shall be housed in a NEMA 7, 9 cast aluminum enclosure.
- 3. Duct heaters shall consist of industrial grade Indeeco stainless steel finned tubular electric heating elements mounted in a heavy-gauge galvanized steel frame.
- 4. Duct heaters shall be furnished with the control option indicated below (select one):
  - Single stage on/off control with field installed thermostat.
  - Multi-stage control with built-in step controller and field installed thermostat.
  - Solid-state control with built-in zero-cross switching SCR and field installed thermostat.
- 5. The following options are to be included:
  - Built-on disconnect switch.
  - Supplementary fusing for heaters drawing less than 48 amps.
  - Warning pilot light to indicate overtemperature or no airflow.
  - "Heater On" pilot light to indicate power to the heater.
  - Disconnecting magnetic contactors.
  - Built-on airflow switch in place of the fan relay.
  - 24 volt transformer in place of 120 volt transformer.
  - NEMA 4, 7, 9 gasketed box for wet locations.



# Typical Wiring Diagrams

Illustrated on these pages are typical wiring diagrams for Indeeco open coil and finned tubular duct heaters.

Wiring diagrams shipped with many heaters are semi-typical in nature, showing various alternates for certain components and illustrating Special Features which may not be supplied on the heater in question. However, check blocks on each wiring diagram are marked to indicate which of the alternates or Special Features apply. The wiring diagrams also indicate the appropriate field wiring gauges and the amp rating of any fuses provided.

## Control Option G, Single Stage Three-Phase

Open Coil

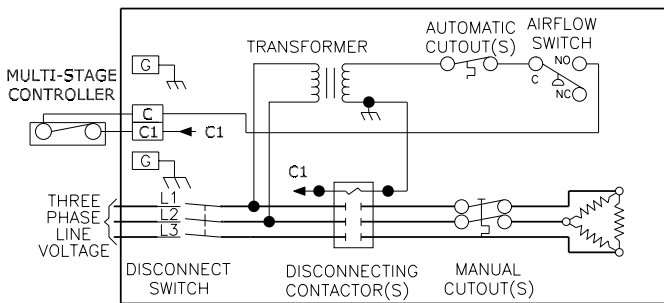

Diagram-1

Finned Tubular

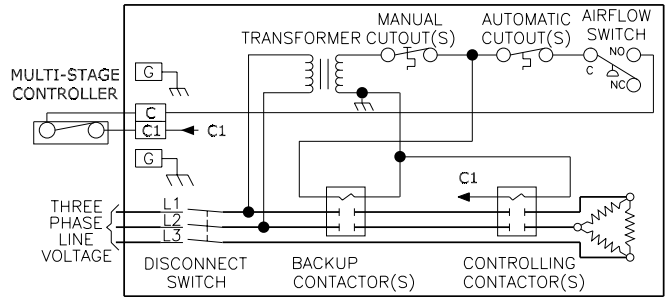

Diagram-2

## Control Option G, Single Stage with Fan Relay, Three-Phase

Open Coil

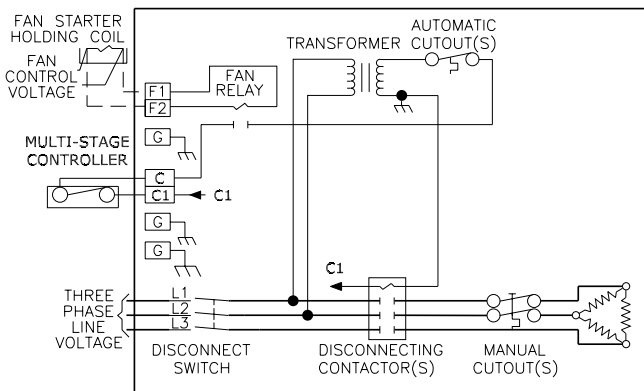

Diagram-3

Finned Tubular

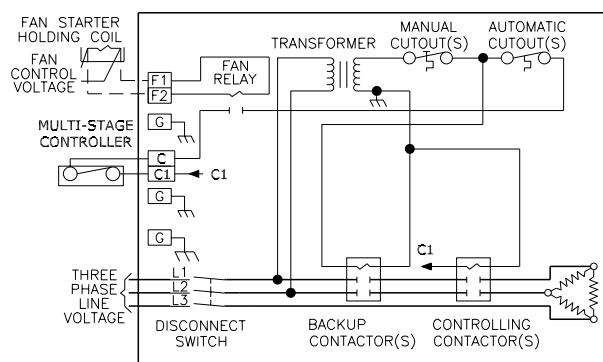

Diagram-4

# Typical Wiring Diagrams

## Control Option G, Multiple Stages, Single-Phase

Open Coil

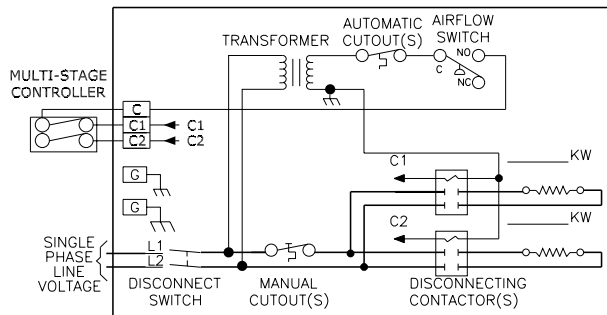

Diagram-5

Finned Tubular

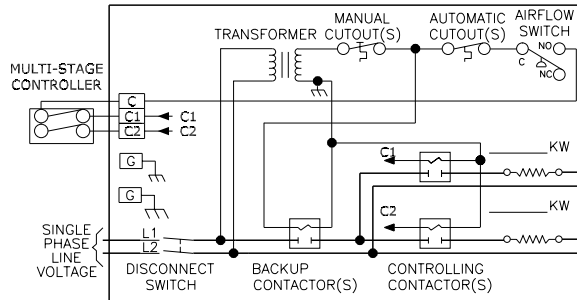

Diagram-6

## Control Option G, Multiple Stages with Electronic Step Controller, Three-Phase

Open Coil

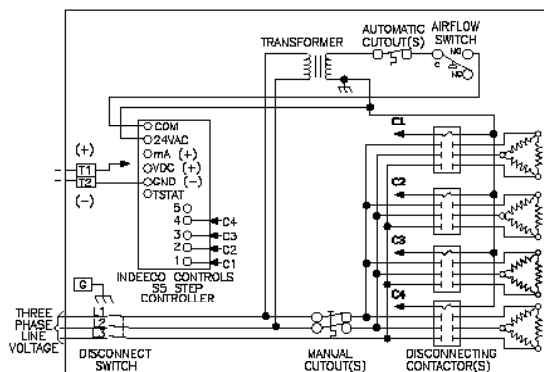

Diagram-7

Finned Tubular

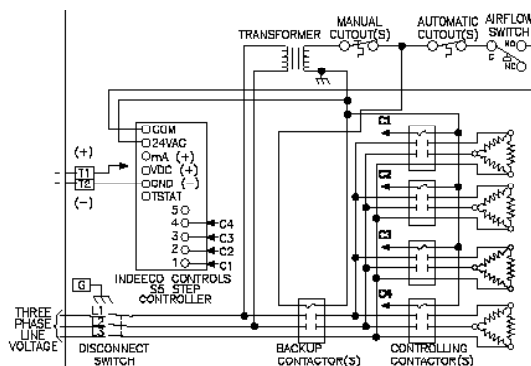

Diagram-8

## Control Option K, SCR, Three-Phase

Open Coil

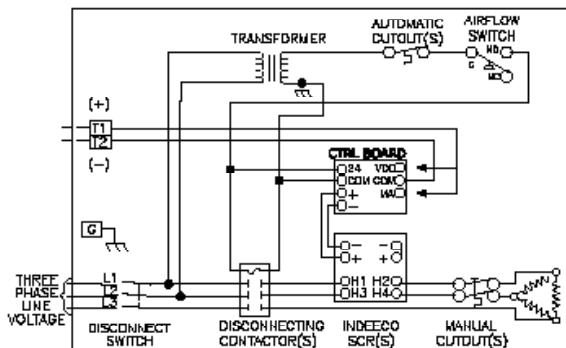

Diagram-9

Finned Tubular

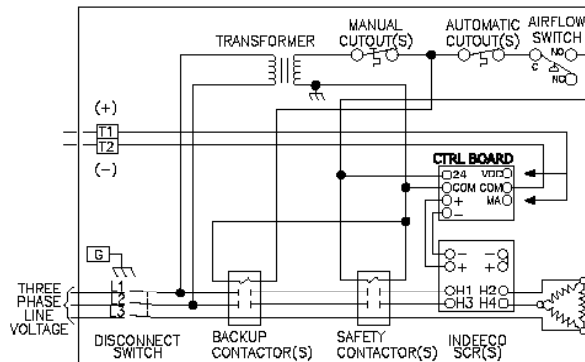

Diagram-10

# Typical Wiring Diagrams

## Control Option K, with a Proportional Room or Duct Thermostat, Three-Phase

Open Coil

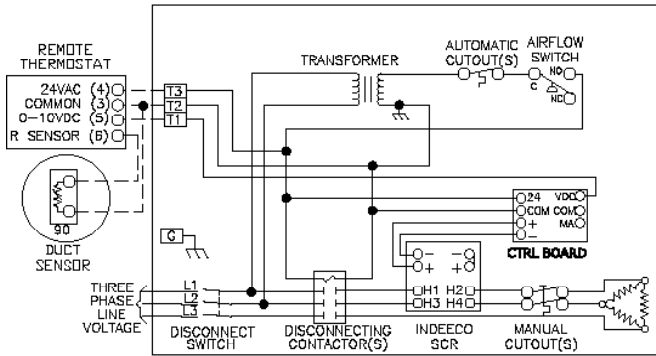

Diagram-11

Finned Tubular

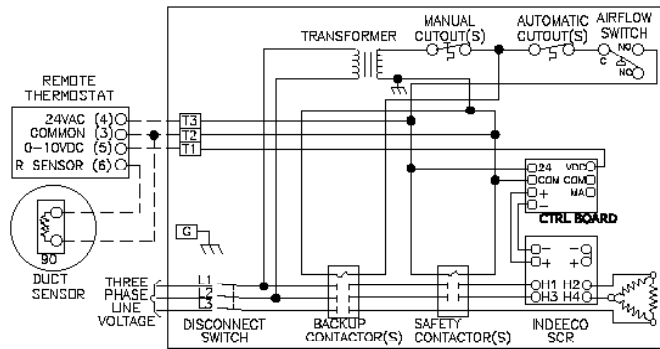

Diagram-12

## Control Option K, SCR Vernier Control, Three-Phase

Open Coil

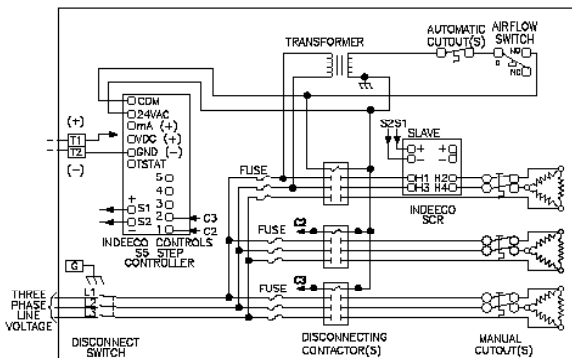

Diagram-13

Finned Tubular

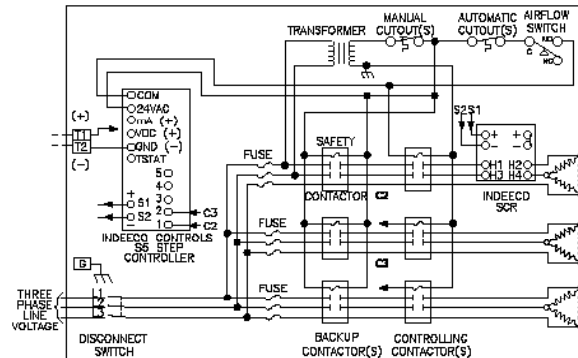

Diagram-14

## Control Option K, SCR Vernier Control, Remote Control Panel, Three-Phase

Open Coil

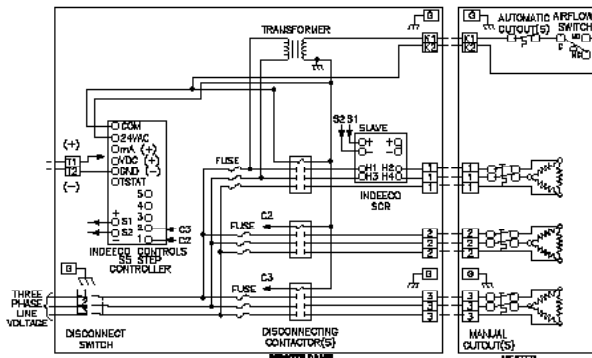

Diagram-15

Finned Tubular

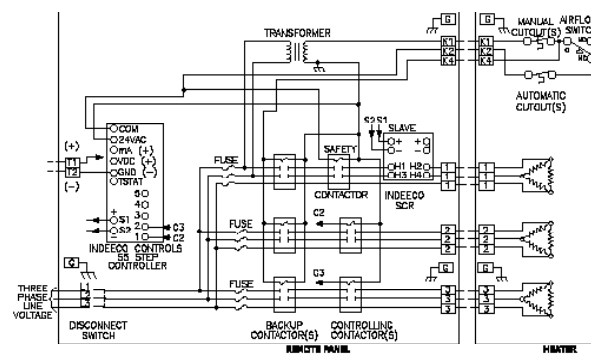
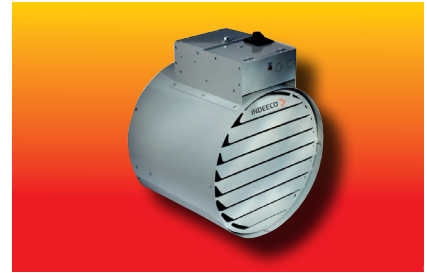

Diagram-16

# More Indeeco Products

## Industrial Unit Heaters

- Ratings from 3 KW through 38 KW.
- Stainless steel finned tubular heating elements.
- Adjustable discharge louvers.
- Bracket for ceiling or wall mounting.
- Built-in controls.
- cULus Listed.



## TRIAD® Washdown and Corrosion Resistant Unit Heaters

- Stainless steel construction with NEMA 4X enclosure.
- Built-in controls.
- Swivel mounting bracket.
- Ratings up to 47 KW.
- cULus Listed and ABS Approved.



## Explosion-proof Unit Heaters

- ULTRA-SAFE™ EXP has industry's lowest ignition temperature code rating.
- Class I & II, Divisions 1 & 2, Groups C, D, E, F & G.
- Built-in controls.
- Small, economical COMPACT designs up to 12 KW.
- CSA and ABS Approved.

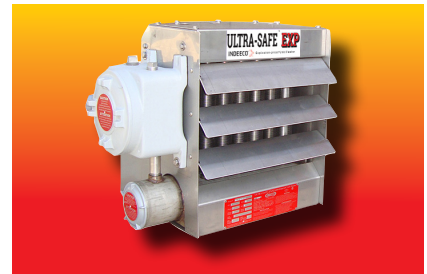

## Explosion-proof Convectors

- Class I & II, Divisions 1 & 2, Groups B, C, D, E, F & G.
- Ratings from 500 to 9,500 watts.
- Sloped-top cabinet design.
- Available with built-in controls.
- CSA and ABS Approved.



# More Indeeco Products



## Comfort Heating Products Forced -Air Heaters

- Cabinet unit heaters range from 2,000 to 24,000 watts. Units may be mounted on the floor, wall or ceiling, and can be recessed for wall or ceiling applications. Full line of optional features available.
- Commercial and architectural wall heaters available from 2,000 to 12,000 watts.
- Ceiling heaters for surface, T-Bar, or recessed mounting with voltage up to 480 VAC, 3-phase and up to 10,000 watts.

## Baseboard Heaters

- Heavy-duty baseboard heaters for commercial, architectural, or industrial applications. Available in flat or sloped top design with a durable epoxy/polyester powder paint finish on a heavy gauge aluminum and steel cabinet. Sizes range from 300 to 4,000 watts.
- Architectural convectors provide large amounts of heat without the fan noise associated with the unit heaters. Can be floor or wall mounted, and fully recessed with a front warm air outlet.

## Unit Heaters

- Heavy-duty commercial unit heaters, offered to 50KW, can be mounted horizontally or vertically. Each heater is available with both ceiling and wall mounting brackets for easy installation.

# Introduction

Indeeco designs and manufactures commercial and industrial electric heating and control systems that set the industry standard for excellence. The company's heating solutions reflect more than 85 years of innovation, product quality and efficient service. Indeeco's innovation, PC HEAT®, is custom software that enables our representatives to respond to your requests for pricing and sizing of open coil and finned tubular duct heaters within minutes. With this software, your local Indeeco representative becomes the source for certified prints, wiring diagrams — complete submittal information.

Our heaters and controls range from the simplest standard duct heater to the most sophisticated, custom designed comprehensive system. Indeeco's attention to detail and rigorous testing give worldwide customers premium products that they receive quickly and at a fair market price.

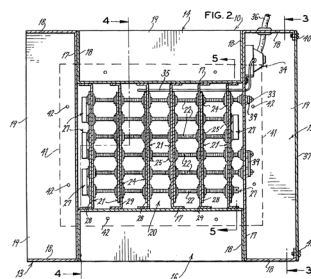

# Limited Warranty

Indeeco new products are warranted against defects in workmanship, material, design, labeling and packaging. No other warranty, expressed or implied, written or oral, applies. No person other than an officer or the general manager of Indeeco is authorized to give any other warranty or assume any liability.

## Warranty Period

Warranty periods differ between product lines. See chart on following page for item specific warranty periods.

## Conditions of Warranty

Indeeco products must be installed, operated, and maintained in accordance with Indeeco's instructions. Indeeco is not liable for damage or unsatisfactory performance of the product resulting from accident, negligence, alteration, unauthorized repair, improper application or installation of the product, improper specifications, or corrosion. Indeeco IS NOT LIABLE FOR ANY INCIDENTAL OR CONSEQUENTIAL DAMAGES. Claims against carriers for damage in transit must be filed by the purchaser with the carrier.

## Remedy

Contact Indeeco sales department at (314) 644-4300 or sales@Indeeco.com, for a Return Material Authorization Number (RMA#) and return instructions.

If after receipt of the product and the claim, Indeeco finds to its reasonable satisfaction that the product is defective in workmanship, material, design, labeling or packaging, the product will be repaired or replaced, or the purchase price refunded at Indeeco's option. There will be no charge to the purchaser for parts or labor. Removal and reinstallation of the product, and shipment of the product to Indeeco for repair or inspection, shall be at the purchaser's risk and expense.

THE REPAIR, REPLACEMENT, OR REFUND PROVIDED FOR IN THIS LIMITED WARRANTY IS THE EXCLUSIVE REMEDY OF THE PURCHASER. THIS WARRANTY IS EXPRESSLY IN LIEU OF ANY OTHER, INCLUDING ANY WARRANTY OF MERCHANTABILITY OR FITNESS FOR A PARTICULAR PURPOSE. THERE ARE NO WARRANTIES WHICH EXTEND BEYOND THE TERMS OF THIS LIMITED WARRANTY.

We have the experience and expertise to provide you with the personalized support to arrive at customized solutions.

Email [sales@indeeco.com](mailto:sales@indeeco.com)  
or call 800.243.8162  
to find your nearest  
Indeeco representative.



When you need more  
than an off-the-shelf,  
standardized product.  
Ask **More.**